

017



Retractors
Wundhaken
Separadores
Ecarteurs
Divaricatori

Wound and Nerve Hooks

Wund- und Hauthäkchen (Nervhäkchen)

Ganchos y ganchitos para nervios

Ecarteurs très fins et crochets à nerfs

Divaricatori finini (Uncini per nervi)

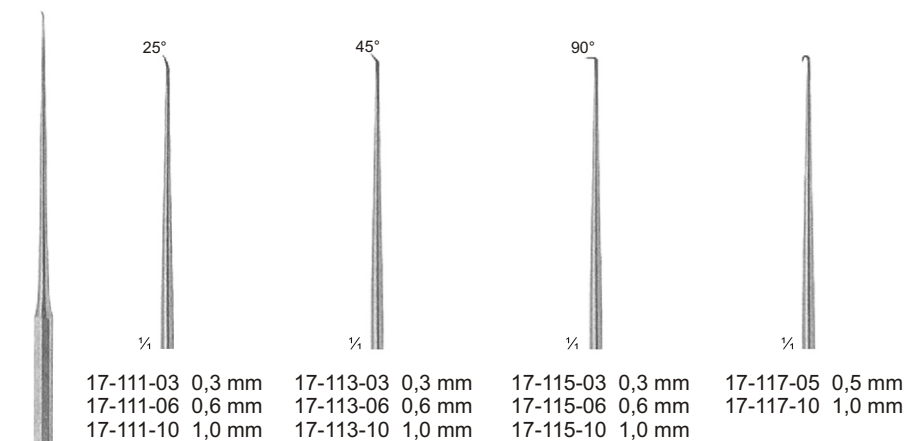

SHAMBAUGH

17-111-03
 17-117-10
 15,5 cm, 6"

Hooks for micro surgery
 Häkchen für die mikrochirurgie
 Ganchos para la microcirugía
 Crochets à microchirurgie
 Crochet per microchirurgia

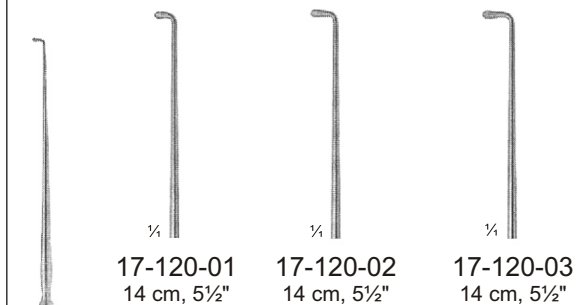

LUCAE

17-120-01
 17-120-03

Ear hooklets
 Ohrhäkchen
 Ganchitos auriculares
 Crochets auriculaires
 Crochet auricolare

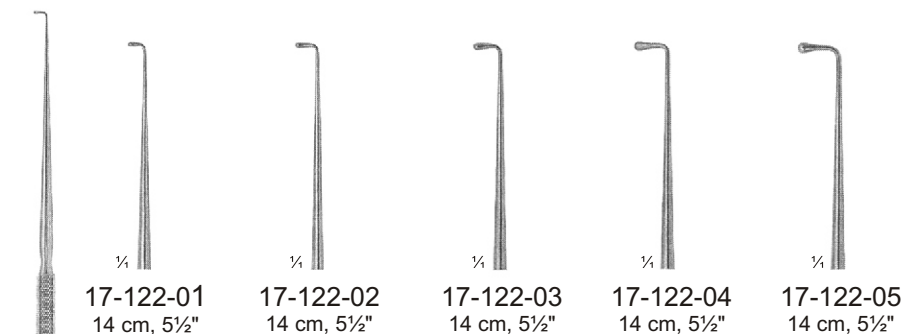

WAGENER

17-122-01
 17-122-05

Ear hooklets
 Ohrhäkchen
 Ganchitos auriculares
 Crochets auriculaires
 Crochet auricolare

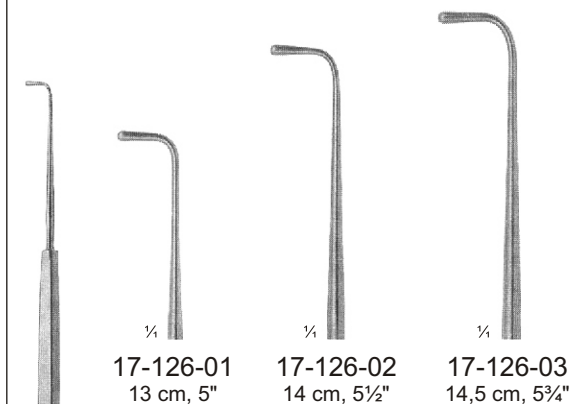

GRAEFE

17-126-01
 17-126-03

Strabismus hooks
 Schielhaken
 Ganchos para estrabismo
 Crochets à strabisme
 Crochet per strabismo



<p>CRILE 17-130-14 17-130-20</p>	<p>CUSHING 17-132-20 17-133-20</p> <p>Blunt Stumpf Romo Mousse Smusso</p> <p>Sharp Spitz Agudo Pointu Acuto</p>	<p>CUSHING 17-136-01 17-136-02</p>	<p>ADSON 17-138-01 17-138-02</p>
---	--	---	---

<p>CRILE 17-142-18 18,5 cm, 7"</p>	<p>CUSHING 17-143-17 17-144-17</p> <p>Sharp Spitz Agudo Pointu Acuto</p> <p>Blunt Stumpf Romo Mousse Smusso</p>	<p>CUSHING 17-147-01 17-147-02</p> <p>Sharp Spitz Agudo Pointu Acuto</p>	<p>TITAN LIGHT</p> <p>CUSHING 17-148-01 17-148-02 17-148-03</p> <p>CUSHING 17-150-01 17-150-03</p> <p>Titan, Titane, Titano</p>
---	--	--	---

Wound and Nerve Hooks

Wund- und Hauthäkchen (Nervhäkchen)

Ganchos y ganchitos para nervios

Ecarteurs très fins et crochets à nerfs

Divaricatori finin (Uncini per nervi)

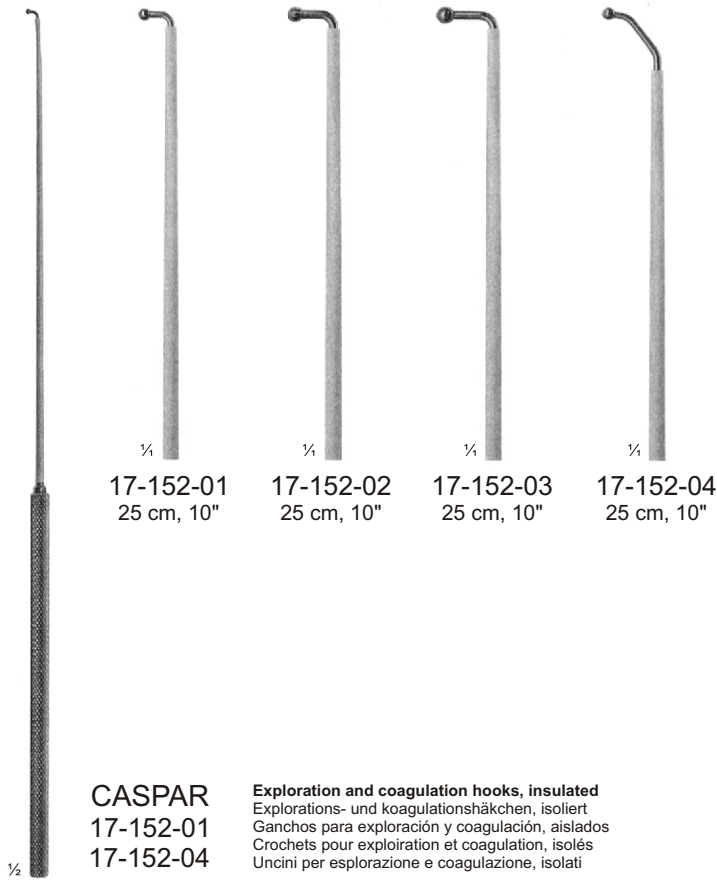

17-152-01 25 cm, 10"
 17-152-02 25 cm, 10"
 17-152-03 25 cm, 10"
 17-152-04 25 cm, 10"

CASPAR
 17-152-01
 17-152-04

Exploration and coagulation hooks, insulated
 Explorations- und koagulationshäkchen, isoliert
 Ganchos para exploración y coagulación, aislados
 Crochets pour exploration et coagulation, isolés
 Uncini per esplorazione e coagulazione, isolati

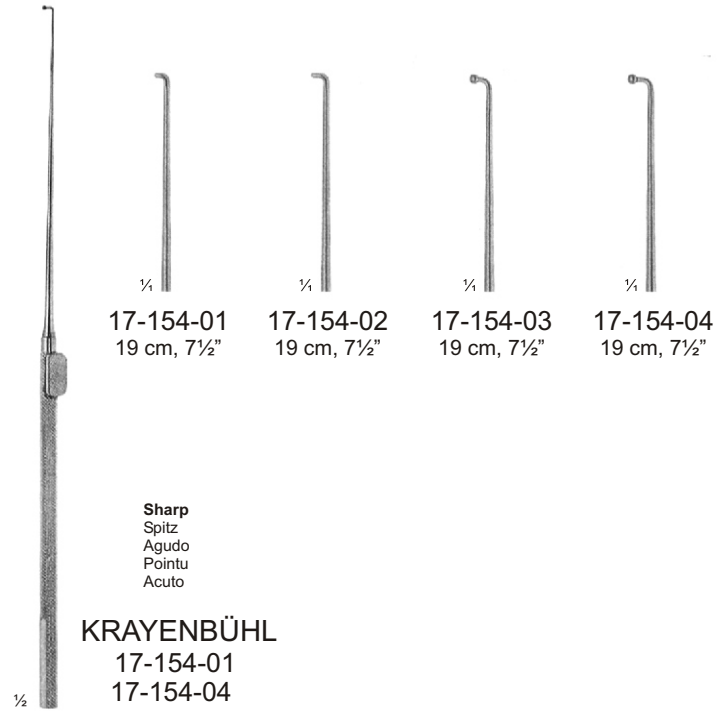

17-154-01 19 cm, 7½"
 17-154-02 19 cm, 7½"
 17-154-03 19 cm, 7½"
 17-154-04 19 cm, 7½"

KRAYENBÜHL
 17-154-01
 17-154-04

Sharp
 Spitz
 Agudo
 Pointu
 Acuto

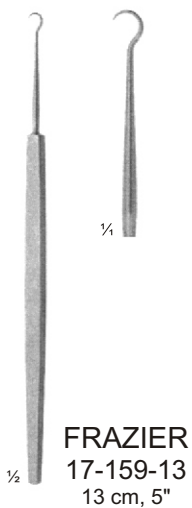

FRAZIER
 17-159-13
 13 cm, 5"

Dura and skin retractor, sharp
 Dura- und Hauthäkchen, spitz
 Gancho para piel y dura-madre, agudo
 Crochet à peau et à dure-mère, pointu
 Divaricatore per pelle e dura-madre, acuto

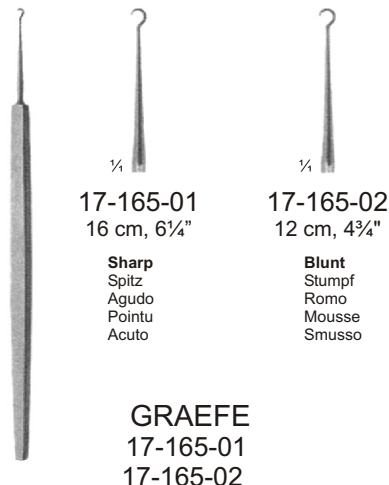

17-165-01 16 cm, 6¼"
 17-165-02 12 cm, 4¾"
Sharp
 Spitz
 Agudo
 Pointu
 Acuto
Blunt
 Stumpf
 Romo
 Mousse
 Smusso

Skin retractors (Iris hooks)
 Hauthäkchen (Iris-häkchen)
 Ganchos para piel (gancho para iris)
 Crochets à peau (Iris)
 Divaricatori cutaneo (uncini per iride)

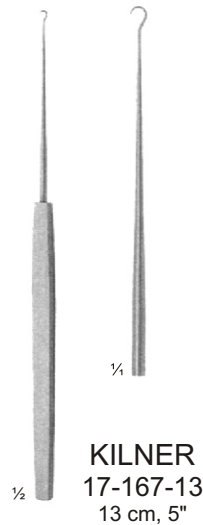

KILNER
 17-167-13
 13 cm, 5"

Skin retractor, sharp
 Hauthäkchen, spitz
 Gancho para piel, agudo
 Crochet à peau, pointu
 Divaricatore cutaneo, acuto

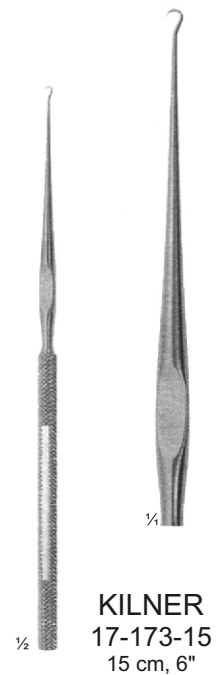

KILNER
 17-173-15
 15 cm, 6"

Skin retractor, sharp
 Hauthäkchen, spitz
 Gancho para piel, agudo
 Crochet à peau, pointu
 Divaricatore cutaneo, acuto

Wound and Nerve Hooks

Wund- und Hauthäkchen (Nervhäkchen)

Ganchos y ganchitos para nervios

Ecarteurs très fins et crochets à nerfs

Divaricatori finin (Uncini per nervi)

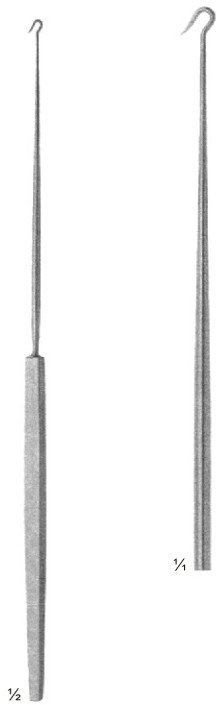

GILLIES
17-177-18
18 cm, 7"

Skin retractor, sharp
Hauthäkchen, spitz
Gancho para piel, agudo
Crochet à peau, pointu
Divaricatore cutaneo, acuto

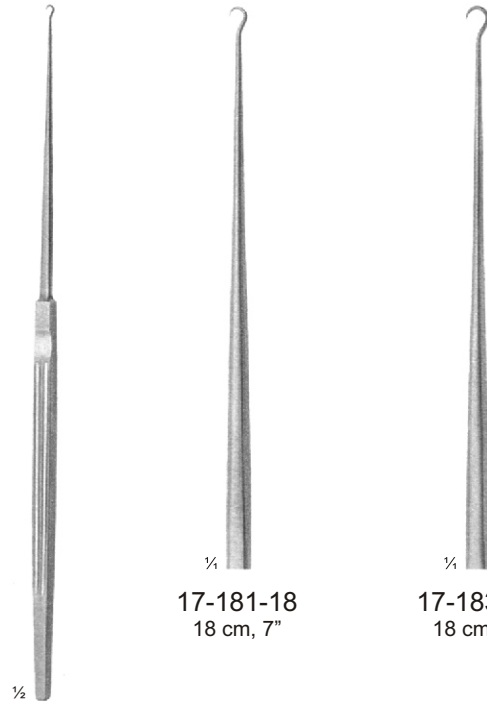

17-181-18
18 cm, 7"

17-183-18
18 cm, 7"

GILLIES(CONVERSE)
17-181-18
17-183-18

Dura and skin retractors, sharp
Dura- und hauthäkchen, spitz
Ganchos para piel, y dura-madre, agudo
Crochets à peau et à dure-mère, pointus
Divaricatori per pelle e dura-madre, acuto

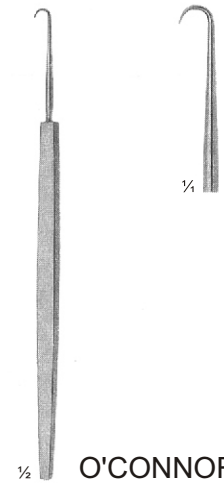

O'CONNOR
17-185-12
12,5 cm, 5"
17-185-16
16 cm, 6¼"

Skin retractor (iris hook), sharp
Hauthäkchen (irishäkchen), spitz
Gancho para piel (gancho para iris), agudo
Crochet à peau (iris), pointu
Uncino cutaneo (uncino per iride), acuto

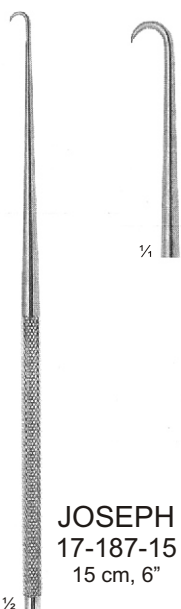

JOSEPH
17-187-15
15 cm, 6"

Hook for plastic surgery, sharp
Häkchen für plastische Chirurgie, spitz
Gancho para cirugía plástica, agudo
Crochet pour la chirurgie plastique, pointu
Uncino per chirurgia plastica, acuto

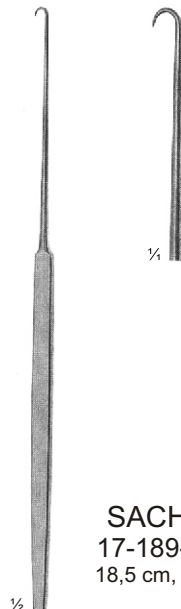

SACHS
17-189-18
18,5 cm, 7¼"

Dura hook, sharp
Durahäkchen, spitz
Gancho para dura-madre, agudo
Crochet pour la dure-mère, pointu
Uncino per dura-madre, acuto



17-193-16
16,5 cm, 6½"

Sharp
Spitz
Agudo
Pointu
Acuto

17-194-17
17 cm, 6¾"

Blunt
Stumpf
Romo
Mousse
Smusso

GRAHAM
17-193-16
17-194-17

Dura hook, blunt
Durahäkchen, stumpf
Gancho para dura-madre, romo
Crochet pour la dure-mère, mousse
Uncino per dura-madre, smusso

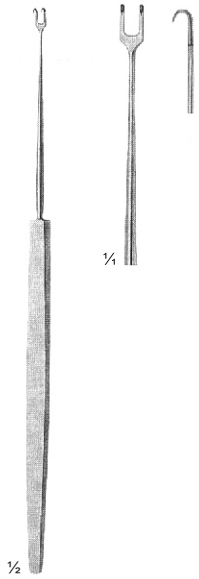

FREER
 17-197-15
 15 cm, 6"

Sharp
 Spitz
 Agudo
 Pointu
 Acuto

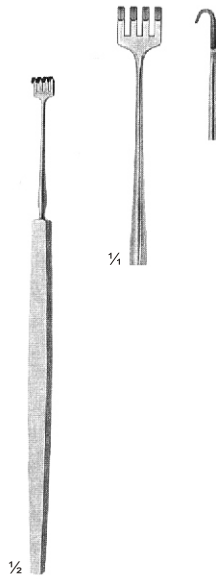

KNAPP
 17-202-14
 14 cm, 5½"

Blunt
 Stumpf
 Romo
 Mousse
 Smusso

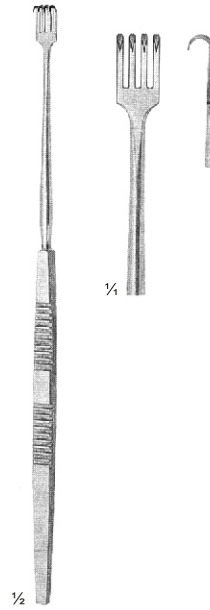

KNAPP
 17-203-16
 16 cm, 6¼"

Sharp
 Spitz
 Agudo
 Pointu
 Acuto

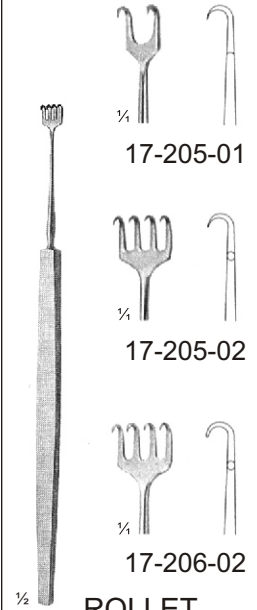

ROLLET
 17-205-01
 17-206-02
 14 cm, 5½"

Sharp
 Spitz
 Agudo
 Pointu
 Acuto

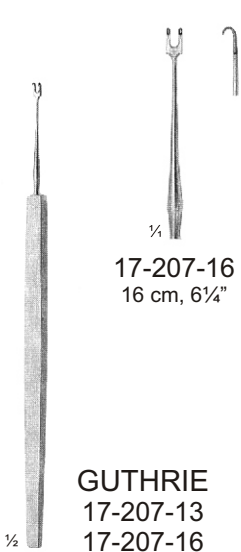

17-207-16
 16 cm, 6¼"

GUTHRIE
 17-207-13
 17-207-16

Skin retractor (iris hook), sharp
 Hauthäkchen (Irishäkchen), spitz
 Gancho para piel (gancho para iris), agudo
 Crochet à plaies (Iris), pointu
 Divaricatore cutaneo (uncino per iride), acuto



17-207-13
 13 cm, 5¼"



JOSEPH
 17-211-01
 17-211-04

Hooks for plastic surgery, sharp
 Häkchen für plastische Chirurgie, spitz
 Ganchos para cirugía plástica, agudos
 Crochets pour la chirurgie plastique, pointu
 Uncini per chirurgia plastica, acuti



17-211-01
 16 cm, 6¼"



17-211-02
 16 cm, 6¼"



17-211-03
 16 cm, 6¼"



17-211-04
 16 cm, 6¼"



17-213-01
16 cm, 6¼"

17-213-02
16 cm, 6¼"

17-213-03
16 cm, 6¼"

17-213-04
16 cm, 6¼"

17-213-01
17-213-04

Trachea retractors, sharp / flexible
 Trachealhäkchen, spitz / flexibel
 Separadores para la tráquea, agudos / flexibles
 Ecarteurs pour trachéotomie, pointu / flexible
 Uncini tracheali, acuti / flessibili

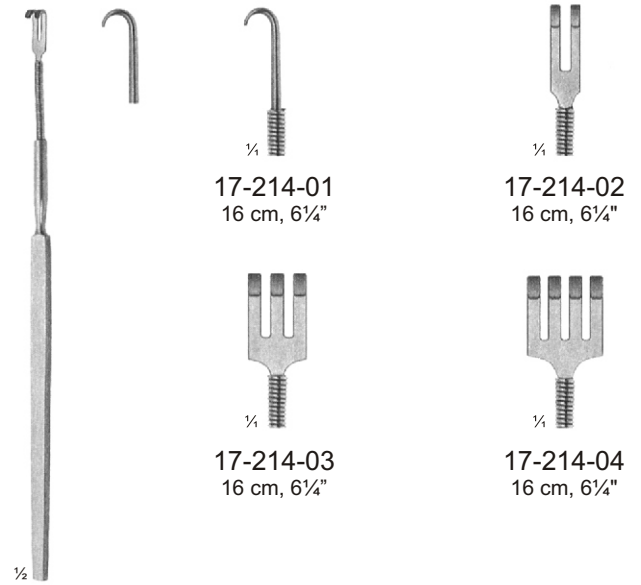

17-214-01
16 cm, 6¼"

17-214-02
16 cm, 6¼"

17-214-03
16 cm, 6¼"

17-214-04
16 cm, 6¼"

17-214-01
17-214-04

Trachea retractors, blunt / flexible
 Trachealhäkchen, stumpf / flexibel
 Separadores para la tráquea, romos / flexibles
 Ecarteurs pour trachéotomie, mousse / flexible
 Uncini tracheali, smussi / flessibili

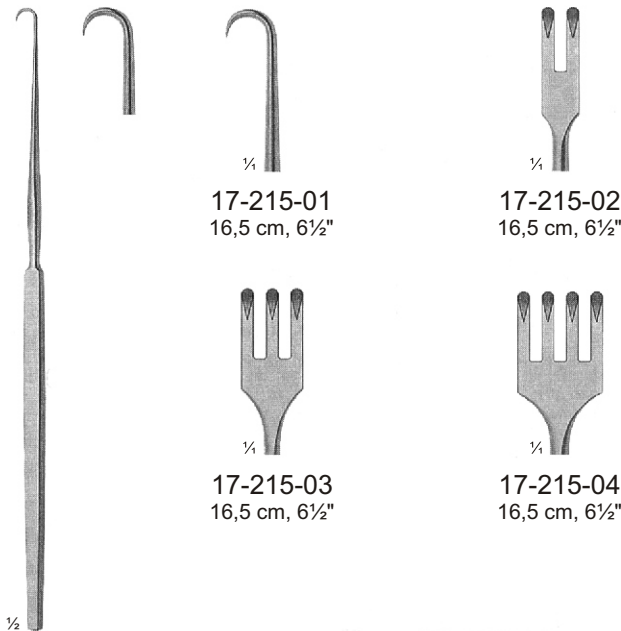

17-215-01
16,5 cm, 6½"

17-215-02
16,5 cm, 6½"

17-215-03
16,5 cm, 6½"

17-215-04
16,5 cm, 6½"

17-215-01
17-215-04

Trachea retractors, sharp
 Trachealhäkchen, spitz
 Separadores para la tráquea, agudos
 Ecarteurs pour trachéotomie, pointu
 Uncini tracheali, acuti

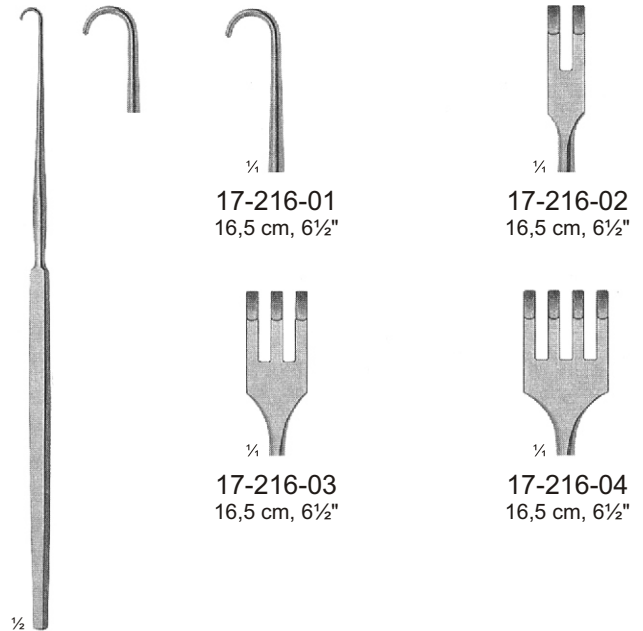

17-216-01
16,5 cm, 6½"

17-216-02
16,5 cm, 6½"

17-216-03
16,5 cm, 6½"

17-216-04
16,5 cm, 6½"

17-216-01
17-216-04

Trachea retractors, blunt
 Trachealhäkchen, stumpf
 Separadores para la tráquea, romos
 Ecarteurs pour trachéotomie, mousse
 Uncini tracheali, smussi

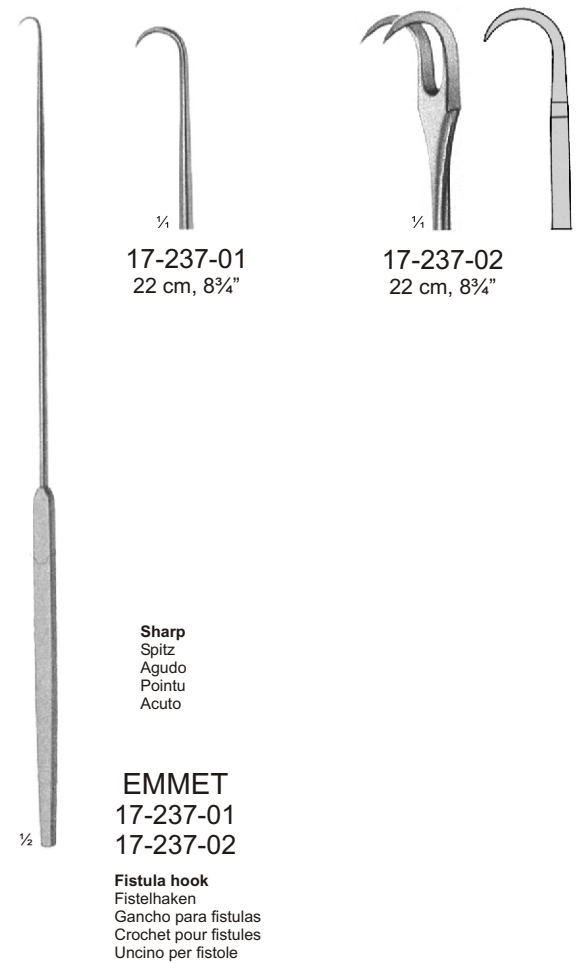
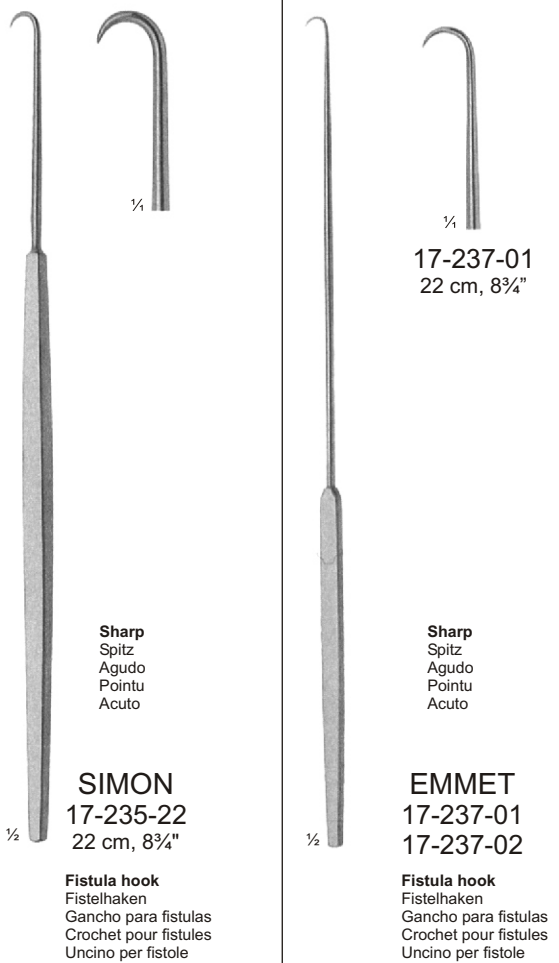
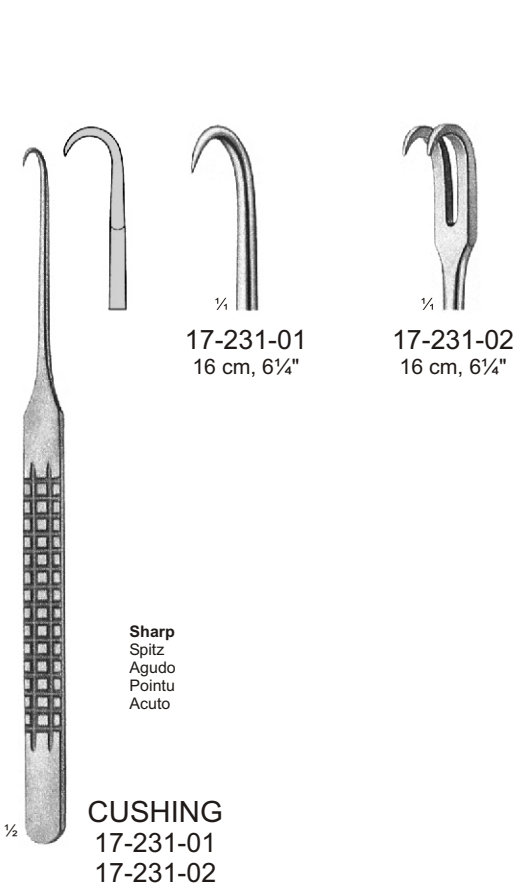
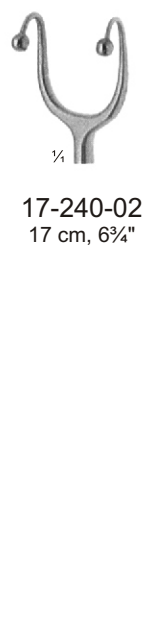
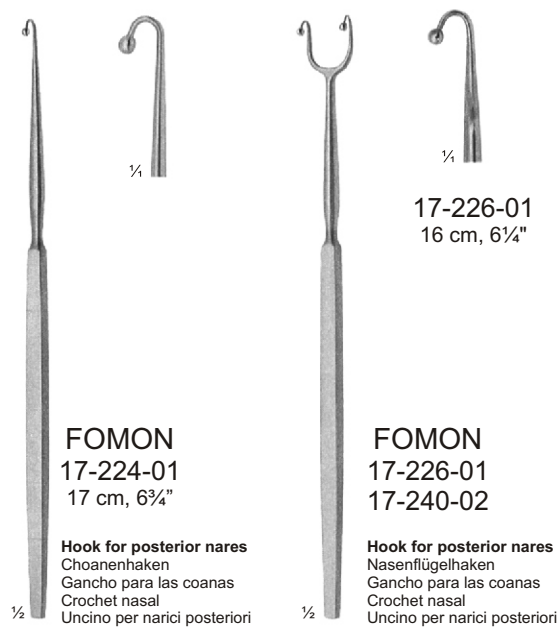
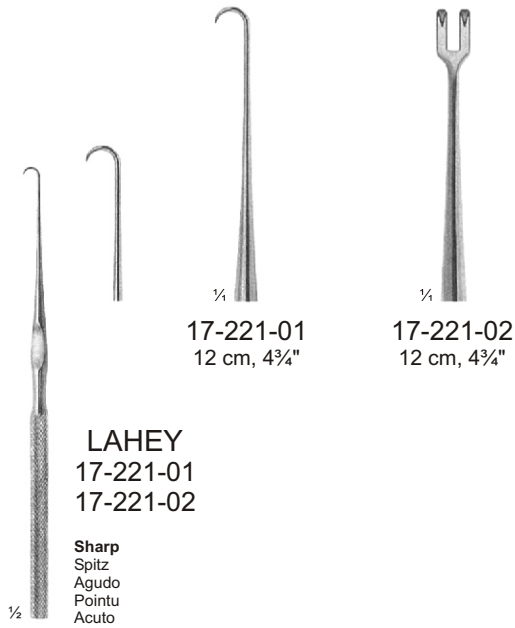



17-250-01
 17-250-01
 17-250-01
 4,5 x 9 mm

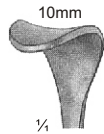

17-250-02
 17-250-02
 17-250-02
 9 x 10 mm

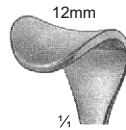

17-250-03
 17-250-03
 17-250-03
 9 x 12 mm

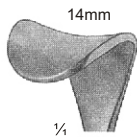

17-250-04
 17-250-04
 17-250-04
 11 x 14 mm

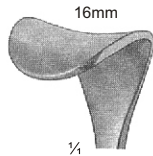

17-250-05
 17-250-05
 17-250-05
 12 x 16 mm

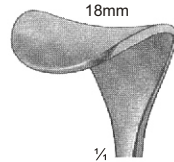

17-250-06
 17-250-06
 17-250-06
 13 x 18 mm

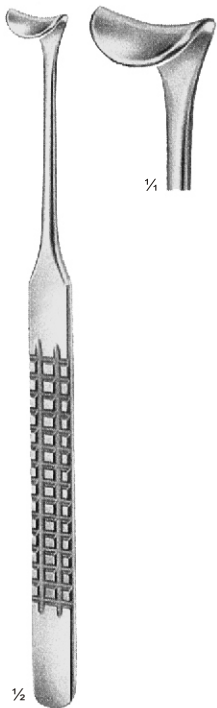

17-250-01
 16 cm, 6¼"
 17-250-06
 16 cm, 6¼"



DESMARRES
 17-254-01
 17-254-06
 13 cm, 5"



CUSHING
 17-256-01
 17-256-06
 20 cm, 8"
Vein retractors
 Venenhaken
 Separadores para venas
 Ecarteurs à veines
 Divaricatori per vene



CUSHING
 17-258-01
 17-258-06
 24 cm, 9½"
Vein retractors
 Venenhaken
 Separadores para venas
 Ecarteurs à veines
 Divaricatori per vene

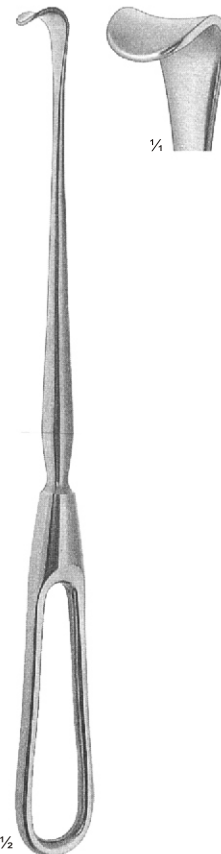

CUSHING
 17-264-23
 23 cm, 9"

Vein retractor
 Venenhaken
 Separador para venas
 Ecartur a veines
 Divaricatore per vene



CUSHING
 17-266-20
 20 cm, 8"

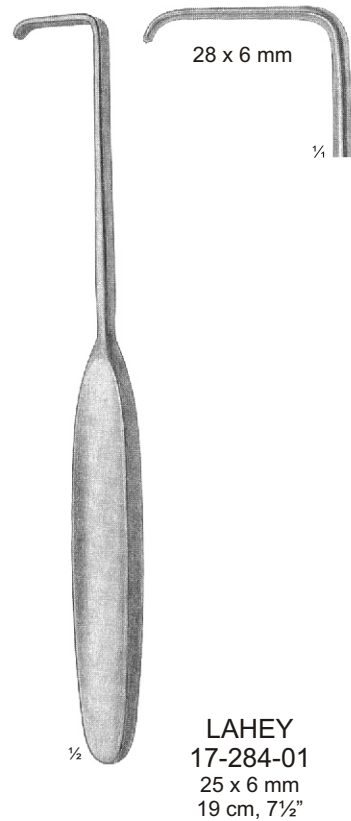
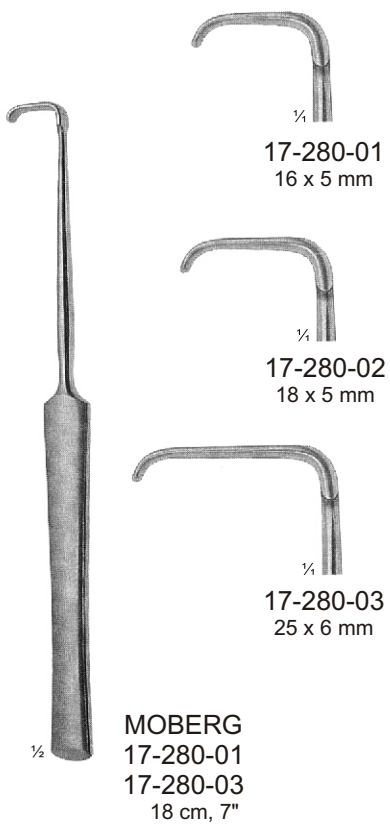
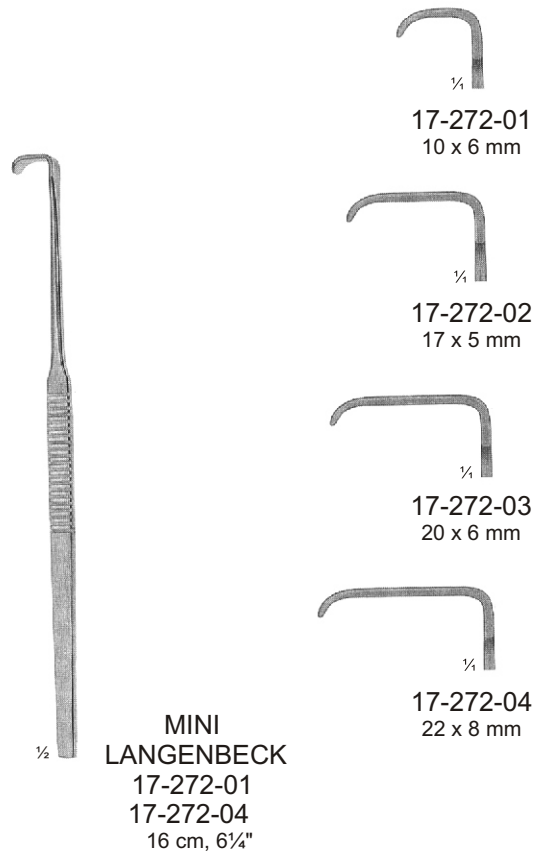
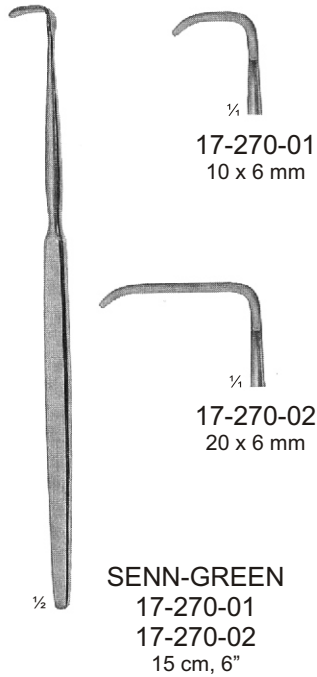

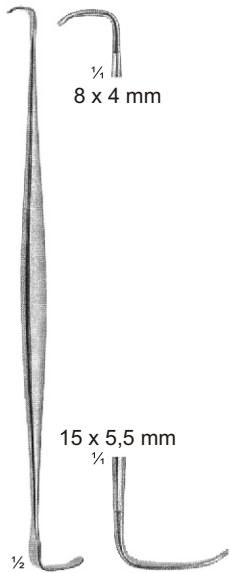

RAGNELL-DAVIS
 17-292-14
 14 cm, 5½"

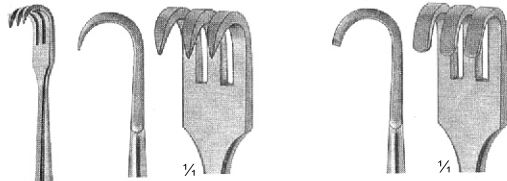

Sharp
 Spitz
 Agudo
 Pointu
 Acuto
 17-293-16

Blunt
 Stumpf
 Romo
 Mousse
 Smusso
 17-294-16

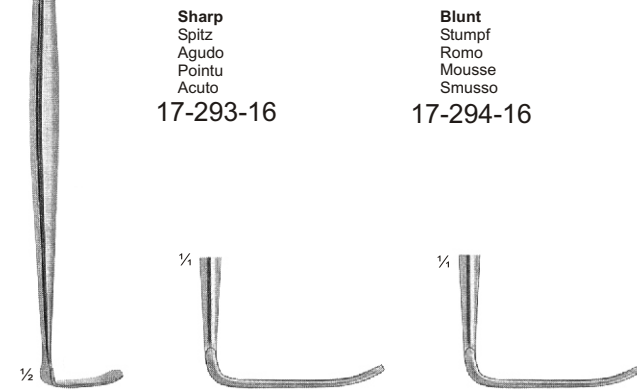

SENN-MILLER
 17-293-16
 17-294-16
 16 cm, 6¼"



CRILE
 17-296-11
 11 cm, 4¼"



LUER
 17-298-11
 11 cm, 4½"

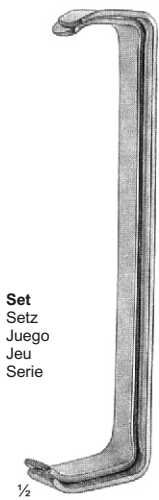

Set
 Setz
 Juego
 Jeu
 Serie

FARABEU
 17-300-12
 12 cm, 4¾"

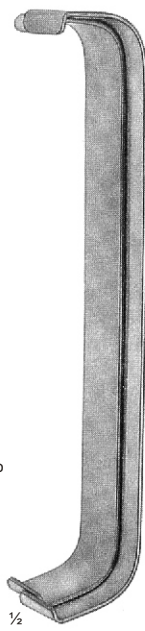

Set
 Setz
 Juego
 Jeu
 Serie

FARABEU
 17-302-15
 15 cm, 5"

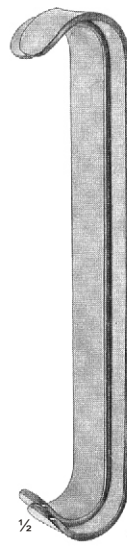

Set
 Setz
 Juego
 Jeu
 Serie

PARKER
 17-308-14
 14 cm, 5¼"

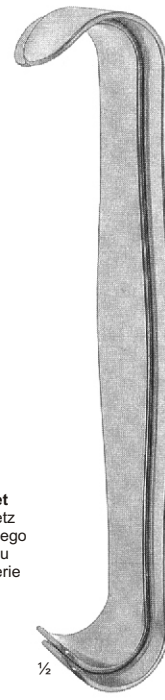

Set
 Setz
 Juego
 Jeu
 Serie

PARKER
 17-310-18
 18 cm, 7"

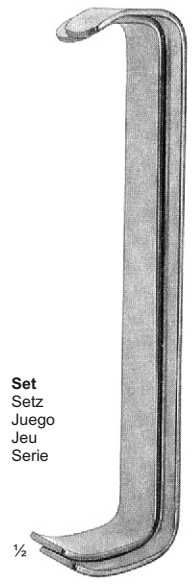

Set
 Setz
 Juego
 Jeu
 Serie

COLLIN
 17-314-17
 17 cm, 6½"



STERNBERG
 17-320-01 12 cm, 4¾"
 17-320-02 14 cm, 5½"
 17-320-03 16 cm, 6¼"

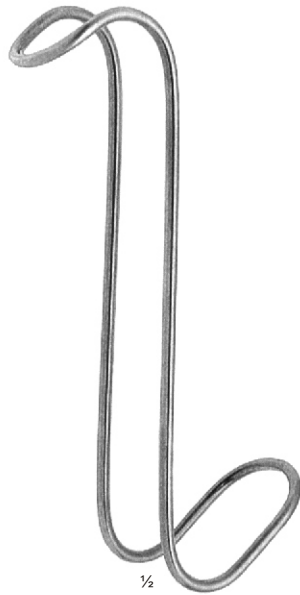

COLLIN-HARTMANN
 17-322-14 14 cm, 5½"
 17-322-16 16 cm, 6¼"



BABY-ROUX
 17-326-13 13 cm, 5¼"

Set, fig 1-3
 Setz Fig 1-3
 Juego fig 1-3
 Jeu fig 1-3
 Serie fig 1-3

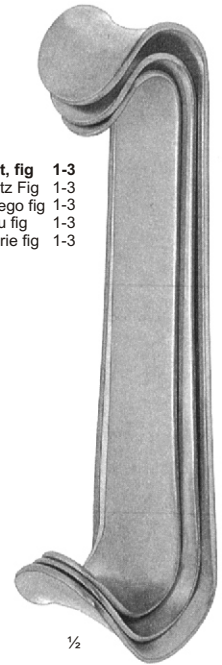

ROUX
 17-328-17 17 cm, 6¾"
 17-328-01 15 cm, 6"
 17-328-02 16 cm, 6¼"
 17-328-03 17 cm, 6¾"

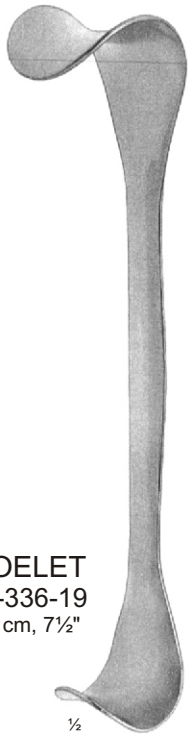

GOELET
 17-336-19 19 cm, 7½"

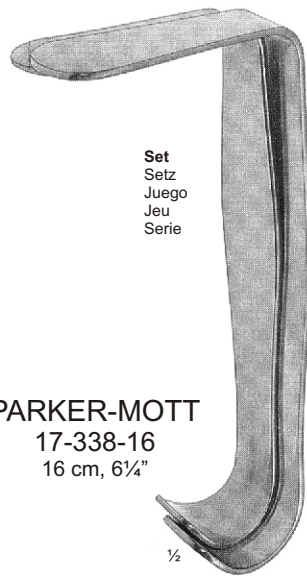

PARKER-MOTT
 17-338-16 16 cm, 6¼"

Set
 Setz
 Juego
 Jeu
 Serie



PARKER-LANGENBECK (US-ARMY)
 17-340-21 21 cm, 8¼"

25X15mm
 21X15mm

Set
 Setz
 Juego
 Jeu
 Serie

40X15mm
 44X15mm



MATHIEU
 17-342-20 20,5 cm, 8"

50X13mm
 44X15mm

Set
 Setz
 Juego
 Jeu
 Serie

40X26mm
 45X26mm



VOLKMANN
17-345-01
17-346-04
11,5 cm, 4½"



17-345-01



17-345-02



17-345-03

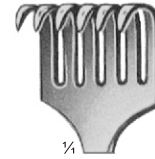

17-345-04

Sharp
Scharf
Agudo
Pointu
Acuto



17-346-01



17-346-02



17-346-03

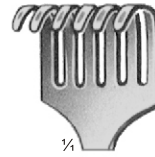

17-346-04

Blunt
Stumpf
Romo
Mousse
Smusso



VOLKMANN
17-347-01
17-348-02
22 cm, 8¾"

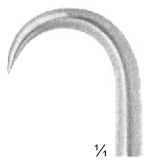

17-347-01
17-349-01

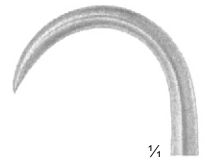

17-347-02
17-349-02

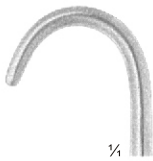

17-348-01
17-350-01

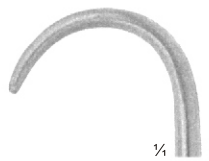

17-348-02
17-350-02

Sharp
Scharf
Agudo
Pointu
Acuto

Blunt
Stumpf
Romo
Mousse
Smusso



VOLKMANN
17-349-01
17-350-02
22 cm, 8¾"



KOCHER
17-351-01
17-352-02
21,5 cm, 8½"

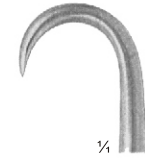

17-351-01
21,5 cm, 8½"

Sharp
Scharf
Agudo
Pointu
Acuto

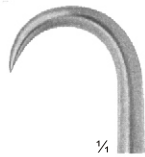

17-351-02
21,5 cm, 8½"

Sharp
Scharf
Agudo
Pointu
Acuto

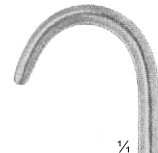

17-352-02
21,5 cm, 8½"

Blunt
Stumpf
Romo
Mousse
Smusso



17-353-01
17-363-01



17-354-01
17-364-01



17-356-01
17-366-01



17-353-02
17-363-02



17-354-02
17-364-02



17-356-02
17-366-02



17-353-03
17-363-03



17-354-03
17-364-03



17-356-03
17-366-03



17-353-04
17-363-04



17-354-04
17-364-04



17-356-04
17-366-04



17-353-05
17-363-05



17-354-05
17-364-05

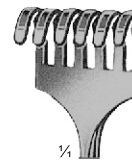

17-356-05
17-366-05

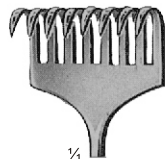

17-353-06
17-363-06

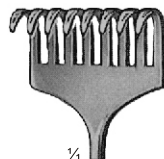

17-354-06
17-364-06

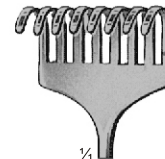

17-356-06
17-366-06

Sharp
Scharf
Agudo
Pointu
Acuto

Semi blunt
Stumpf
Romo
Mousse
Smusso

Blunt
Stumpf
Romo
Mousse
Smusso



1/2
KOCHER
17-353-01
17-355-06
22cm, 8 3/4"

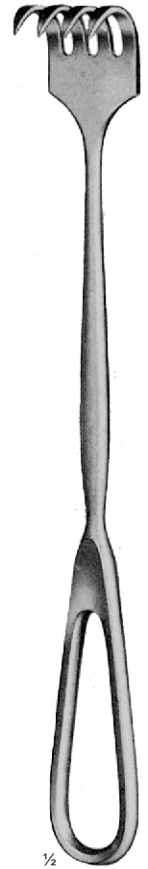

1/2
MARTIN
17-363-01
17-365-06
22cm, 8 3/4"

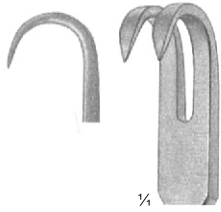

1/4
17-357-01
17-367-01
10 x 8 mm

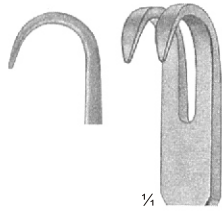

1/4
17-359-01
17-369-01
10 x 8 mm

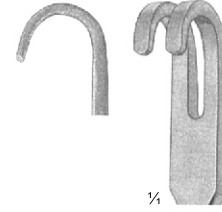

1/4
17-360-01
17-370-01
10 x 8 mm



1/4
17-357-02
17-367-02
10 x 13 mm

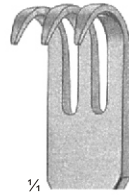

1/4
17-359-02
17-369-02
10 x 13 mm

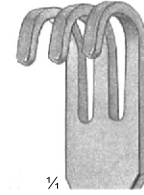

1/4
17-360-02
17-370-02
10 x 13 mm

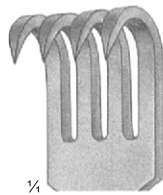

1/4
17-357-03
17-367-03
10 x 18 mm

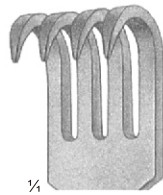

1/4
17-359-03
17-369-03
10 x 18 mm

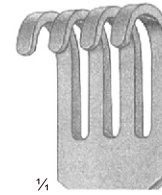

1/4
17-360-03
17-370-03
10 x 18 mm

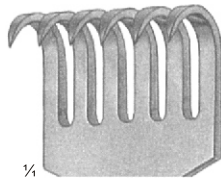

1/4
17-357-04
17-367-04
10 x 28 mm

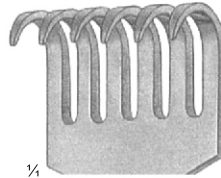

1/4
17-359-04
17-369-04
10 x 28 mm

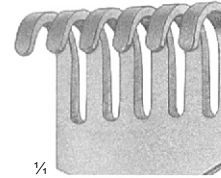

1/4
17-360-04
17-370-04
10 x 28 mm

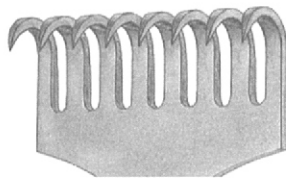

1/4
17-357-05
17-367-05
10 x 40 mm

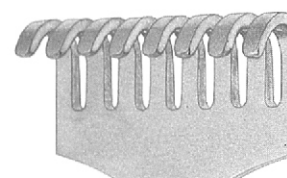

1/4
17-360-05
17-370-05
10 x 40 mm

Semi Sharp
Scharf
Agudo
Pointu
Acuto

Sharp
Scharf
Agudo
Pointu
Acuto

Blunt
Stumpf
Romo
Mousse
Smusso



1/2
VOLKMANN
17-357-01
17-367-05
22 cm, 8 3/4"



1/2
VOLKMANN
17-367-01
17-370-05
23 cm, 9"



Sharp
Scharf
Agudo
Pointu
Acuto



1/4
17-373-01
15 x 9 mm

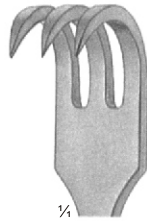

1/4
17-373-02
15 x 13 mm

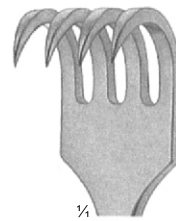

1/4
17-373-03
15 x 18 mm

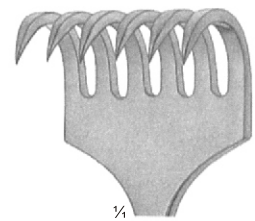

1/4
17-373-04
15 x 30 mm



Semi blunt
Stumpf
Romo
Mousse
Smusso

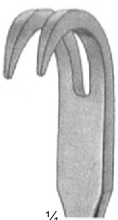

1/4
17-375-01
15 x 9 mm



1/4
17-375-02
15 x 13 mm

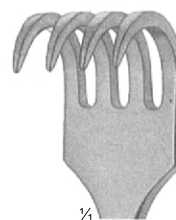

1/4
17-375-03
15 x 18 mm

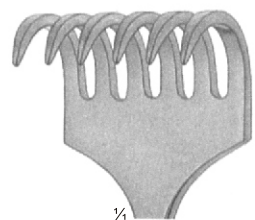

1/4
17-375-04
15 x 30 mm



Blunt
Stumpf
Romo
Mousse
Smusso



1/4
17-376-01
15 x 9 mm

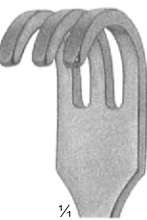

1/4
17-376-02
15 x 13 mm

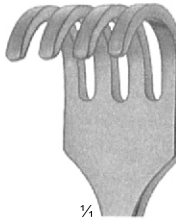

1/4
17-376-03
15 x 18 mm

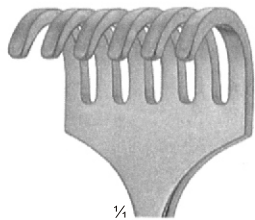

1/4
17-376-04
15 x 30 mm



1/2
KOCHER
17-373-01
17-376-04
22 cm, 8 3/4"



Blunt
Stumpf
Romo
Mousse
Smusso

1/2
OLLIER
17-380-03
22,5 cm, 9"
17-380-04
22,5 cm, 9"



Sharp
Scharf
Agudo
Pointu
Acuto

1/2
KOERTE-WAGNER
17-383-28
28 cm, 11"

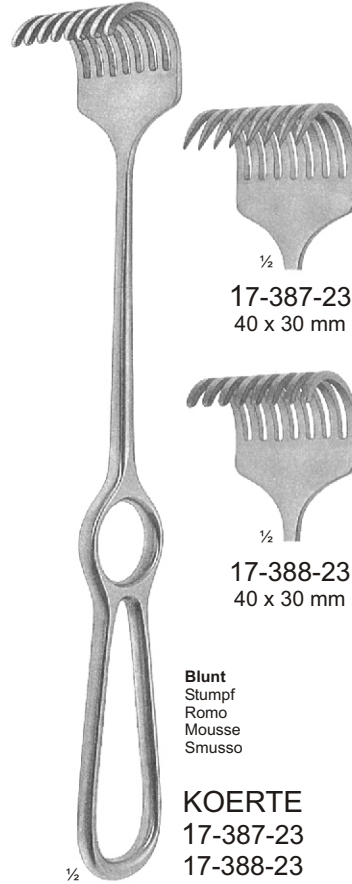

Blunt
Stumpf
Romo
Mousse
Smusso

1/2
KOERTE
17-387-23
17-388-23
23,5 cm, 9 1/4"

Handle vertical to the blade
Griff vertikal zum blatt
Mango vertical a la hoja
Manche vertical à la valve
Impugnatura verticale a lama



Blunt
Stumpf
Romo
Mousse
Smusso

1/2
KOERTE
17-390-23
23,5 cm, 9 1/4"

Handle vertical to the blade
Griff vertikal zum blatt
Mango vertical a la hoja
Manche vertical à la valve
Impugnatura verticale a lama



1/2
ISRAEL
17-396-01
17-396-04
25 cm, 10"
Blunt
Stumpf
Romo
Mousse
Smusso

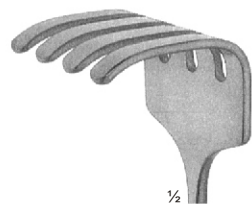

1/2
17-396-01
40 x 40 mm

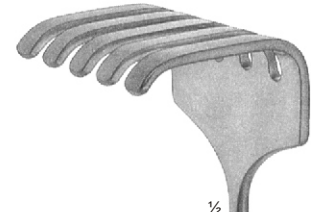

1/2
17-396-02
45 x 50 mm

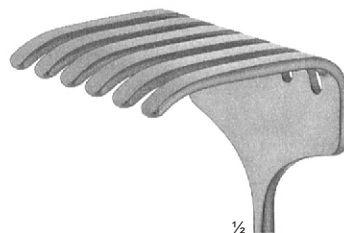

1/2
17-396-03
50 x 60 mm

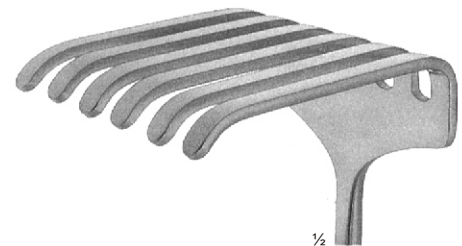

1/2
17-396-04
70 x 70 mm

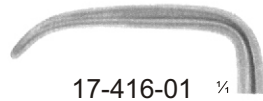

17-416-01 ¼
17-418-01
30 x 11 mm

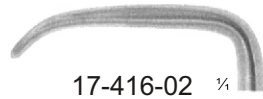

17-416-02 ¼
17-418-02
30 x 14 mm

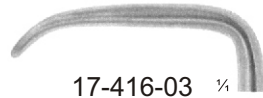

17-416-03 ¼
17-418-03
30 x 16 mm

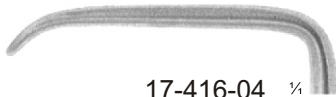

17-416-04 ¼
17-418-04
40 x 10 mm

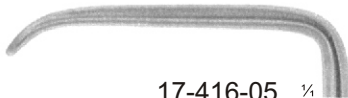

17-416-05 ¼
17-418-05
40 x 11 mm

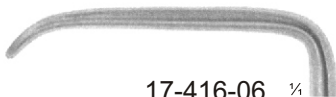

17-416-06 ¼
17-418-06
40 x 15 mm

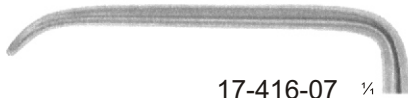

17-416-07 ¼
17-418-07
50 x 11 mm



½

LANGENBECK

17-416-01
17-416-07
21 cm, 8¼"



½

LANGENBECK

17-418-01
17-418-07
22 cm, 8½"



17-420-05 ¼
75 x 40 mm



17-420-04 ¼
75 x 30 mm

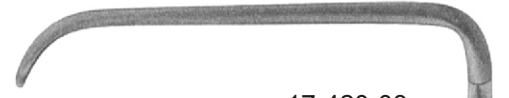

17-420-03 ¼
60 x 25 mm



17-420-02 ¼
60 x 20 mm



17-420-01 ¼
40 x 18 mm



½

KOCHER

17-420-01
17-420-05
23 cm, 9"

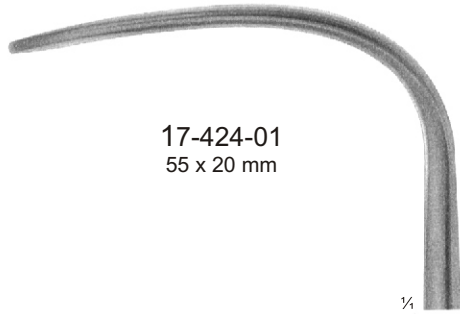

17-424-01
 55 x 20 mm

¼



17-424-02
 60 x 20 mm

¼



½

LANGENBECK
 17-424-01 21,5 cm, 8½"
 17-424-02 21,5 cm, 8½"

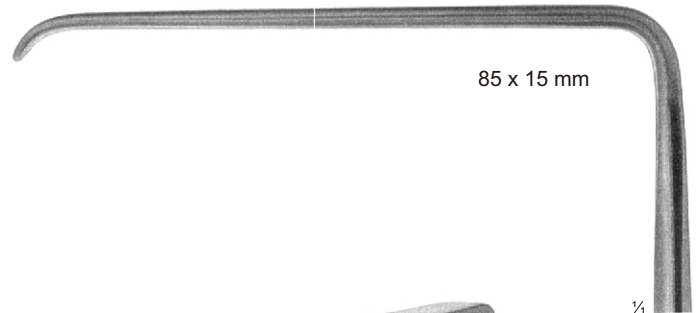

85 x 15 mm

¼



½

LANGENBECK
 17-428-22
 22,5 cm, 8¾"



1/2

**KOCHER
LAGENBECK**
17-434-01
17-434-09
22 cm, 8 1/2"

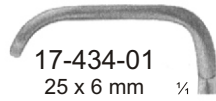

17-434-01
25 x 6 mm 1/4

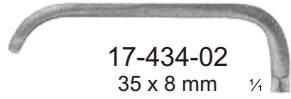

17-434-02
35 x 8 mm 1/4

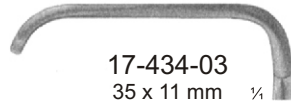

17-434-03
35 x 11 mm 1/4

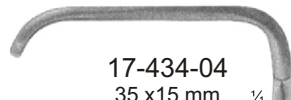

17-434-04
35 x 15 mm 1/4

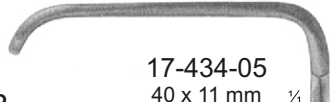

17-434-05
40 x 11 mm 1/4



17-434-06
55 x 11 mm 1/4



17-434-07
70 x 14 mm 1/4



17-434-08
80 x 12 mm 1/4



17-434-09
80 x 16 mm 1/4



1/2

17-440-03 40 x 10 mm
17-440-04 40 x 15 mm
17-440-05 40 x 20 mm 1/4

KOCHER
17-440-01
17-440-05
22 cm, 8 1/2"

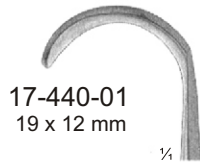

17-440-01
19 x 12 mm 1/4



17-440-02
21 x 14 mm 1/4

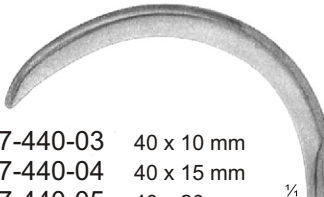

1/2

SAUERBRUCH
17-444-01
17-444-03
25 cm, 10"

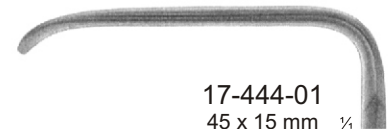

17-444-01
45 x 15 mm 1/4

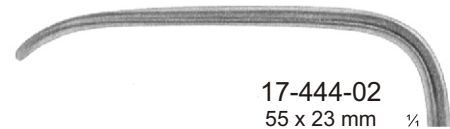

17-444-02
55 x 23 mm 1/4



17-444-03
72 x 20 mm 1/4



17-450-01
25 x 6 mm



17-450-02
8 x 35 mm



17-450-03
40 x 11 mm

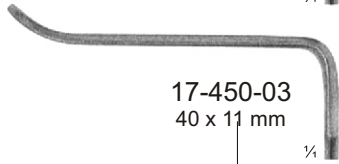

17-450-04
55 x 11 mm

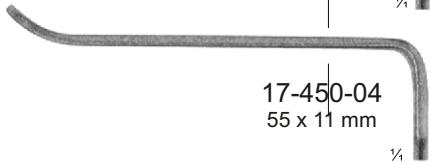

17-450-05
70 x 14 mm



17-450-06
80 x 16 mm



1/2

OBWEGESER
17-450-01
17-450-06
22 cm, 8 3/4"

Soft tissue retractors
Weichteilhaken
Separadores para tejido blando
Ecarteurs pour parties molles
Divaricatori per tessuti molli

17-452-01
23x 6 mm

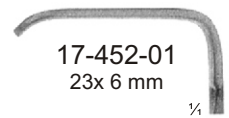

17-452-02
35 x 8 mm

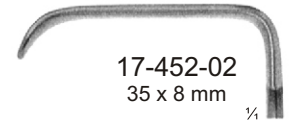

17-452-03
40 x 11 mm

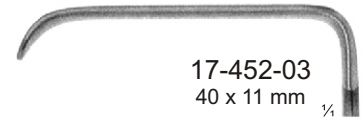

17-452-04
55 x 11 mm



17-452-05
70 x 14 mm

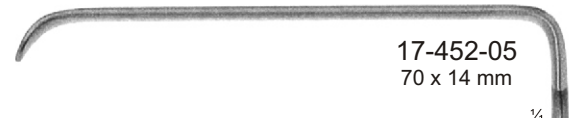

17-452-06
80 x 16 mm

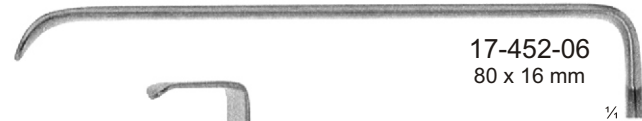

1/2

OBWEGESER
17-452-01
17-452-06
21,5 cm, 8 1/2"

Soft tissue retractors
Weichteilhaken
Separadores para tejido blando
Ecarteurs pour parties molles
Divaricatori per tessuti molli



17-458-01
45 X 45 mm



17-458-02
45 X 50 mm



17-458-03
55 X 70 mm



MIDDELDORPF
17-458-01
17-458-03
25,5 cm, 10"



17-460-01
14 X 17 mm
21,5 cm, 8½"



17-460-02
20 X 22 mm
22,5 cm, 8¾"



17-460-03
26 X 30 mm
23,5 cm, 9½"



MIDDELDORPF
17-460-01
17-460-03



17-466-22
22 x 20 mm



Thyroid gland retractor
Schilddrüsenhaken
Separador para la glándula tiroidea
Ecarteur pour la thyroïde
Divaricatore per la tiroide

GREEN
17-466-22
22 cm, 8¾"

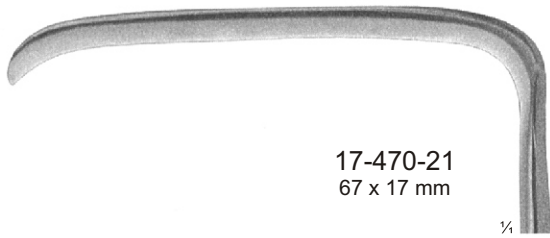

17-470-21
 67 x 17 mm

¼

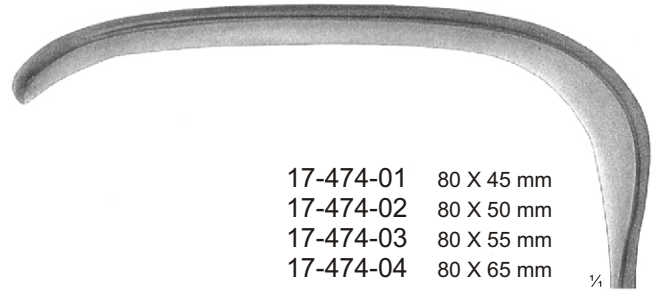

17-474-01 80 X 45 mm
 17-474-02 80 X 50 mm
 17-474-03 80 X 55 mm
 17-474-04 80 X 65 mm

¼



½

CASPAR
 17-470-21
 21,5 cm, 8½"



½

KOCHER
 17-474-01
 17-474-04
 25 cm, 10"



Retractors
Wundhaken
Separadores
Ecarteurs
Divaricatori



017

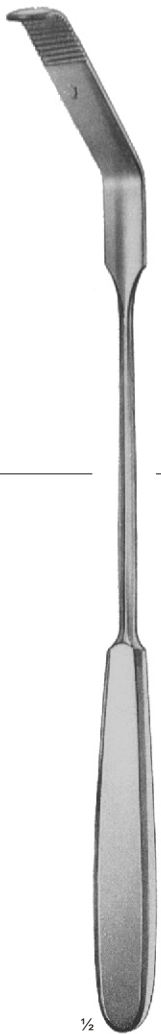

½

ZENKER
17-480-01
17-480-05



½

KOCHER
17-478-01
17-478-05
23 cm, 9"

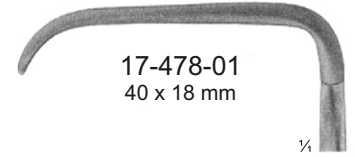

17-478-01
40 x 18 mm

¼

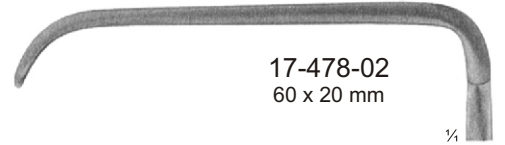

17-478-02
60 x 20 mm

¼

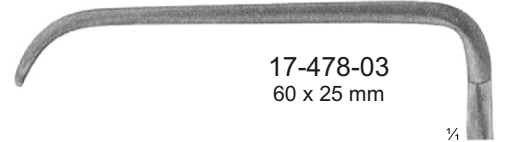

17-478-03
60 x 25 mm

¼



17-478-04
75 x 30 mm

¼



17-478-05
75 x 40 mm

¼

17-480-01
35 x 8 mm
23,5 cm, 9¼"

17-480-02
60 x 12 mm
26 cm, 10¼"

17-480-03
75 x 12 mm
27,5 cm, 10¾"

17-480-04
85 x 20 mm
29 cm, 11¼"

17-480-05
100 x 25 mm
30 cm, 12"

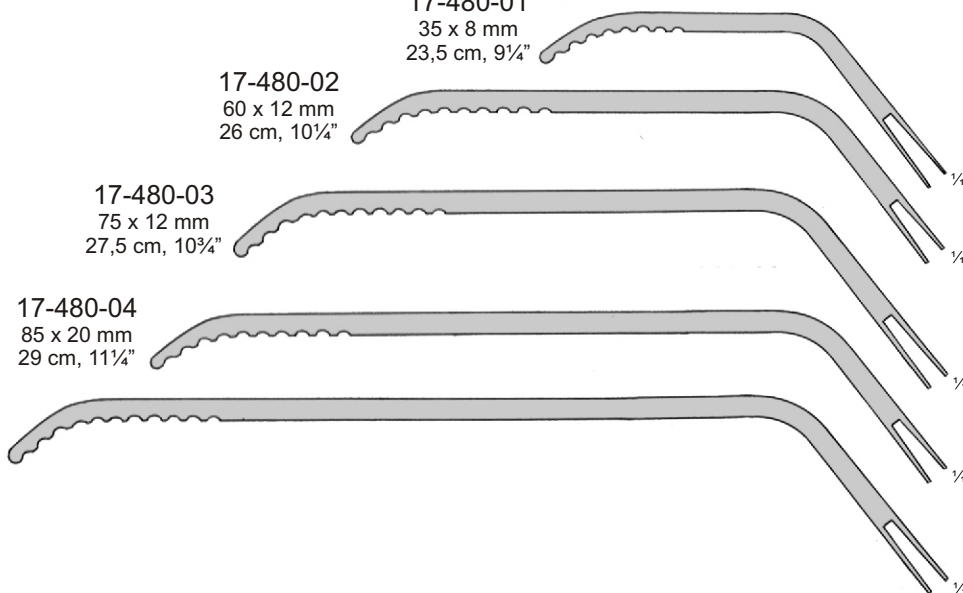

¼

¼

¼

¼

¼



½

DOYEN
 17-488-01
 17-488-11
 23 cm, 9"

Abdominal retractor
 Bauchdeckenhaken
 Separadores abdominales
 Ecarteurs intra abdominaux
 Divaricatori addominale

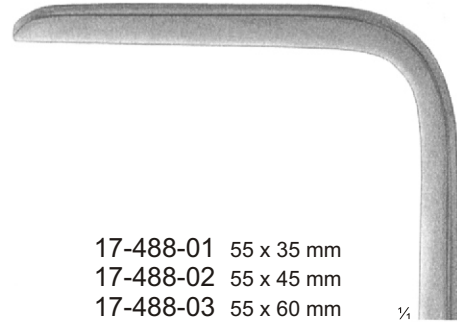

17-488-01 55 x 35 mm
 17-488-02 55 x 45 mm
 17-488-03 55 x 60 mm

¼

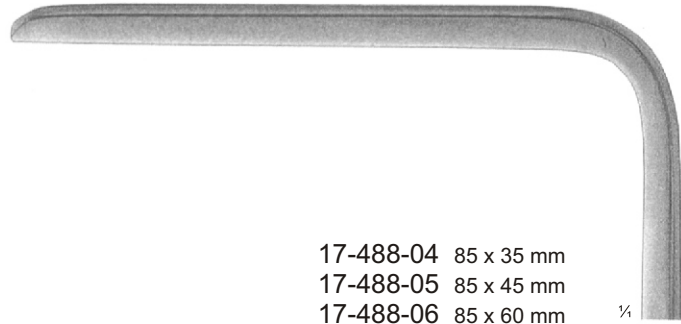

17-488-04 85 x 35 mm
 17-488-05 85 x 45 mm
 17-488-06 85 x 60 mm

¼

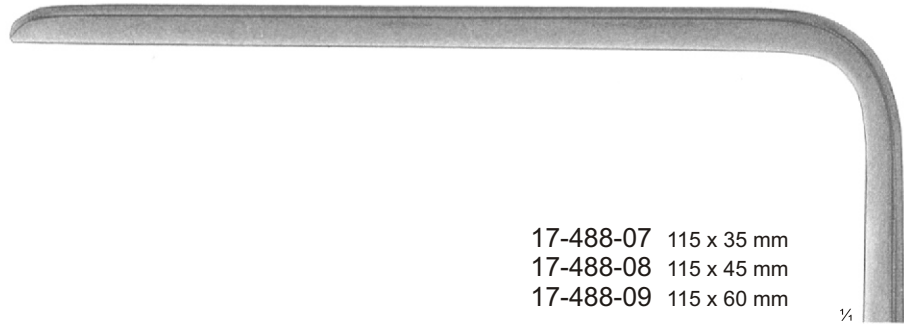

17-488-07 115 x 35 mm
 17-488-08 115 x 45 mm
 17-488-09 115 x 60 mm

¼



17-488-10 160 x 45 mm
 17-488-11 160 x 60 mm

¼



17-492-01 30 x 30 mm
17-492-02 32 x 40 mm

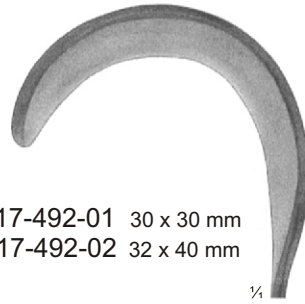

17-492-03 40 x 60 mm
17-492-04 40 x 50 mm

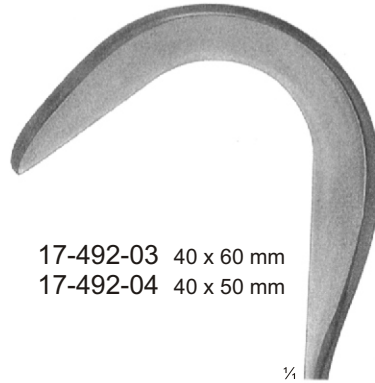

17-494-24
50 x 85 mm



Handle vertical to the blade
Griff vertikal zum Blatt
Mango vertical a la hoja
Manche vertical à la valve
Impugnatura verticale a lama

17-492-05
45 x 75 mm



17-492-06
65 x 85 mm

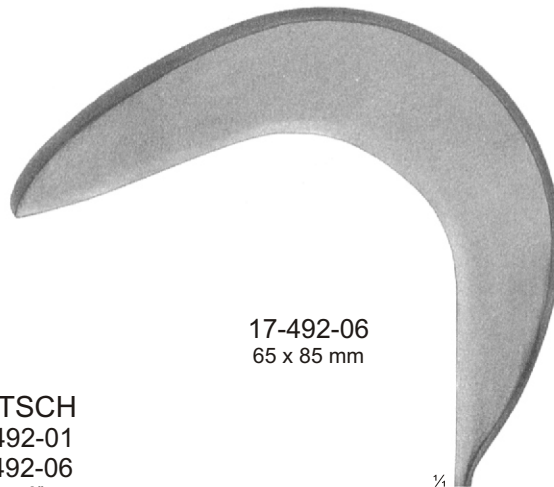

Abdominal retractor
Bauchdeckenhaken
Separador abdominal
Ecarteur intra abdominaux
Divaricatore addominale

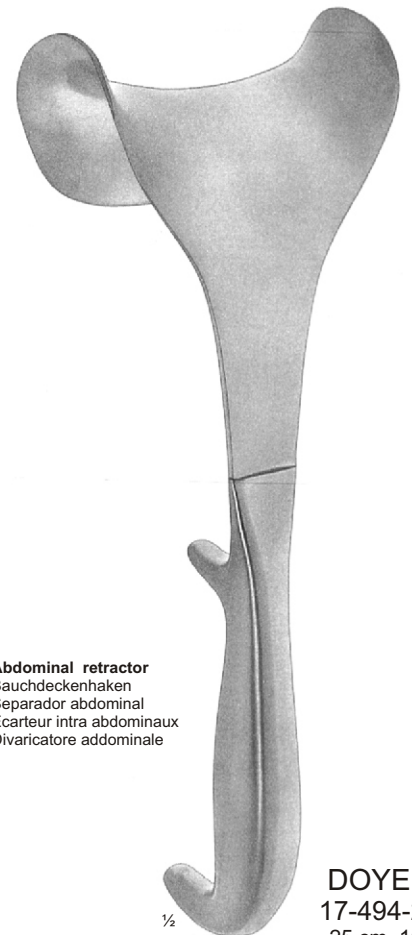

DOYEN
17-494-24
25 cm, 10"

FRITSCH
17-492-01
17-492-06
23 cm, 9"



17-496-01
28 x 20 mm

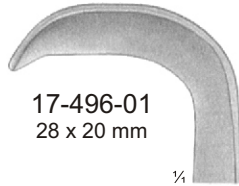

17-496-02
36 x 28 mm



17-496-03
44 x 38 mm

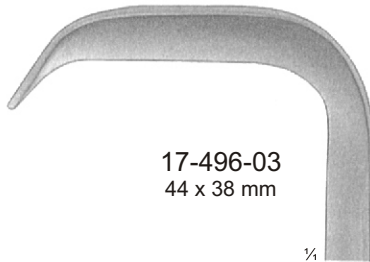

17-496-04
52 x 22 mm

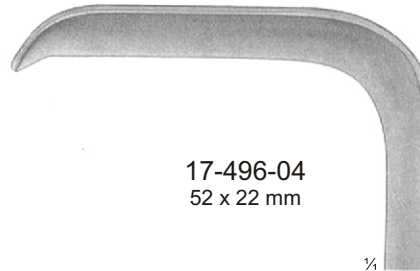

RICHARDSON
17-496-01
17-496-04
24 cm, 9½"

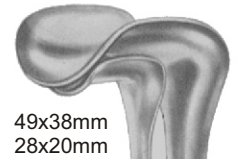

49x38mm
28x20mm

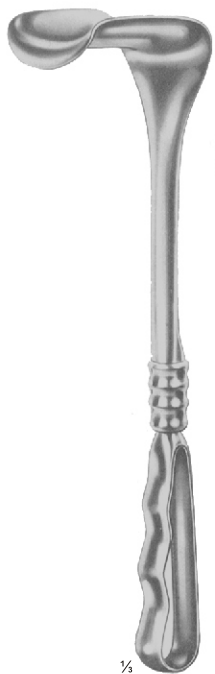

17-498-01
50 x 40 mm

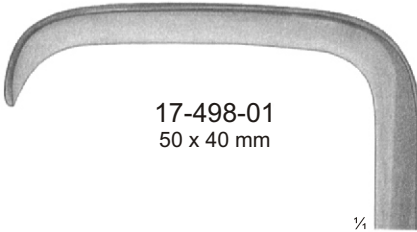

17-498-02
50 x 65 mm

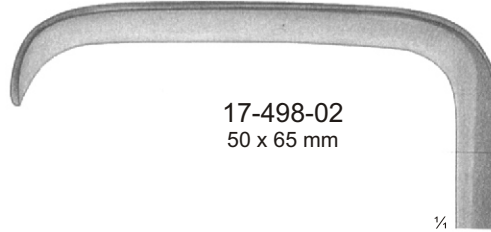

KELLY
17-498-01
17-498-03
26 cm, 10¼"

17-498-03
75 x 65 mm
17-498-04
90 x 75 mm

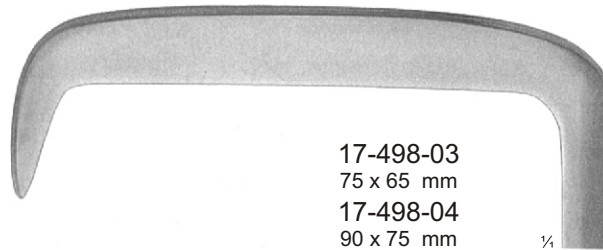

36 x 28mm
71 x 43mm

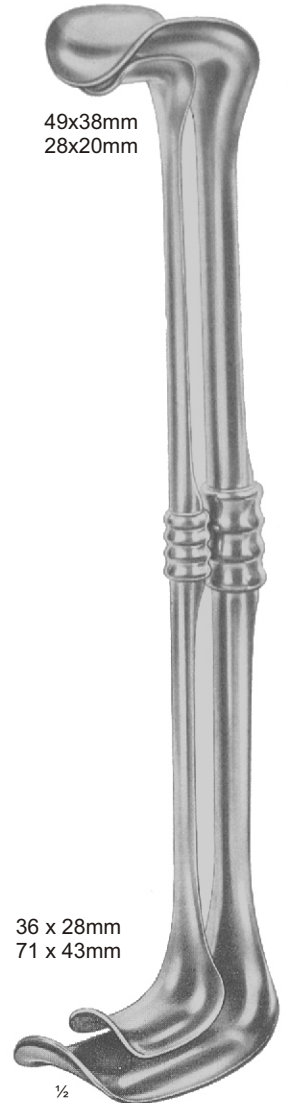

**RICHARDSON
EASTMAN**
17-502-01
17-502-02
26 cm, 10¼"

Set
Satz
Juego
Jeu
Serie

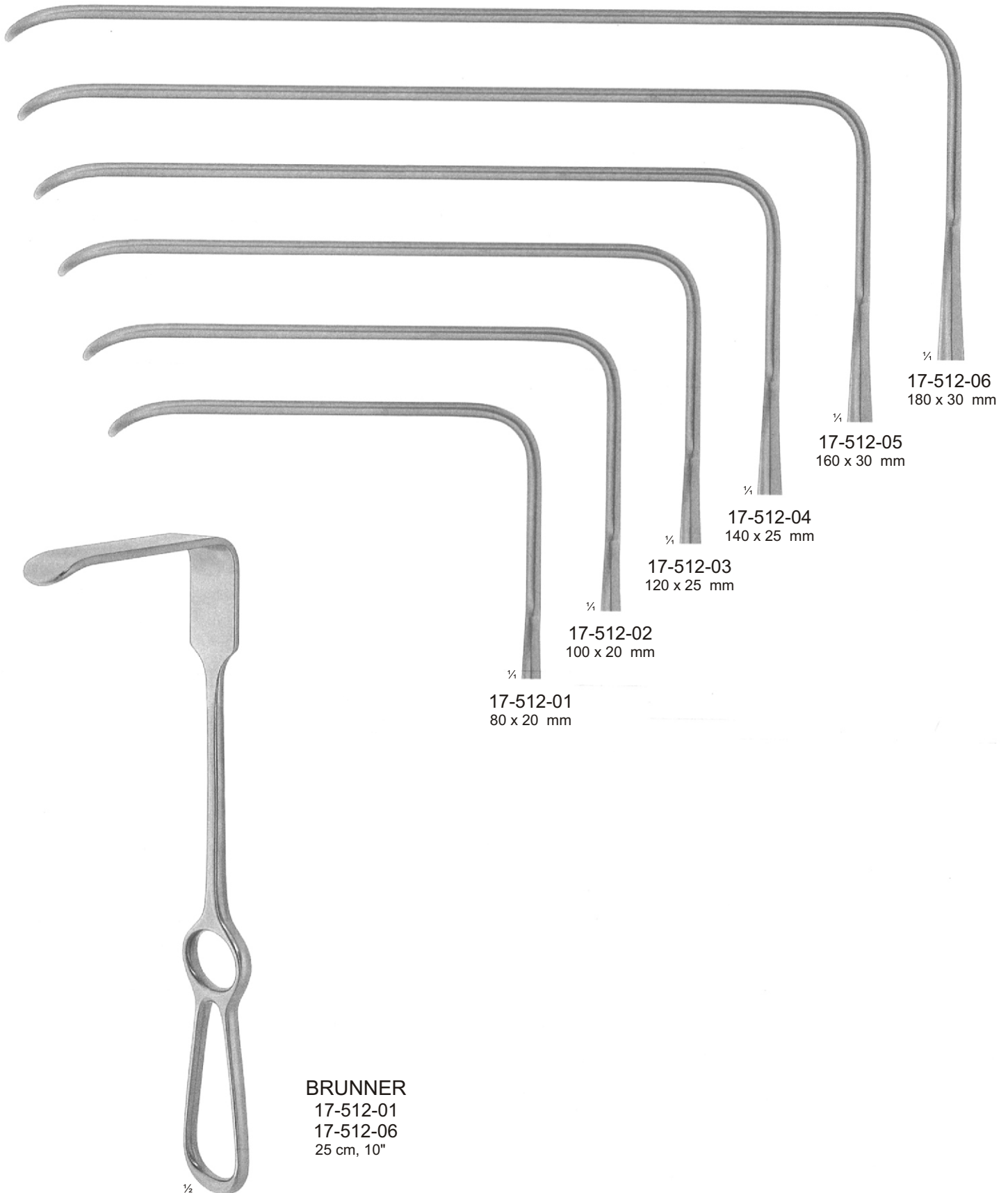

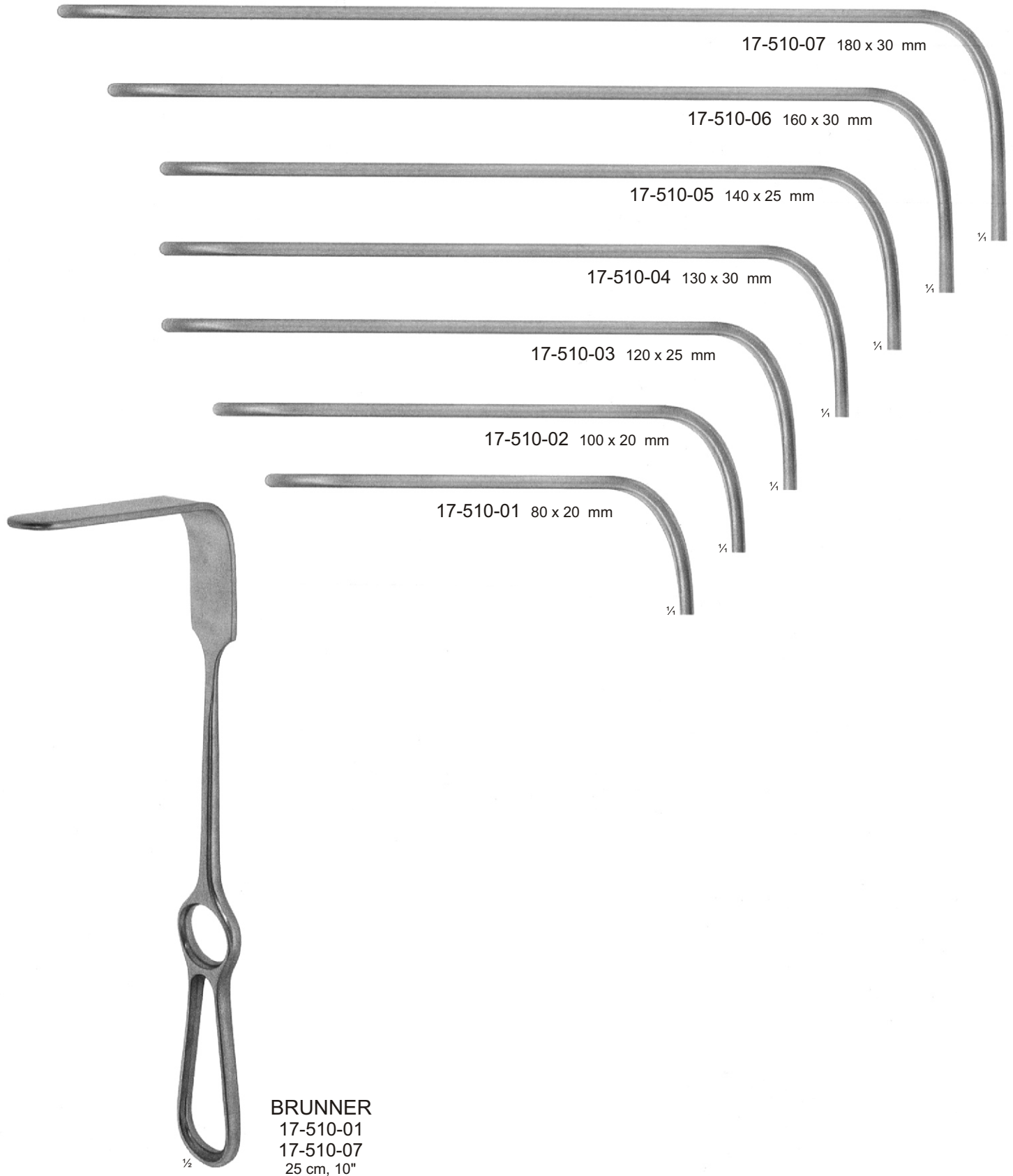

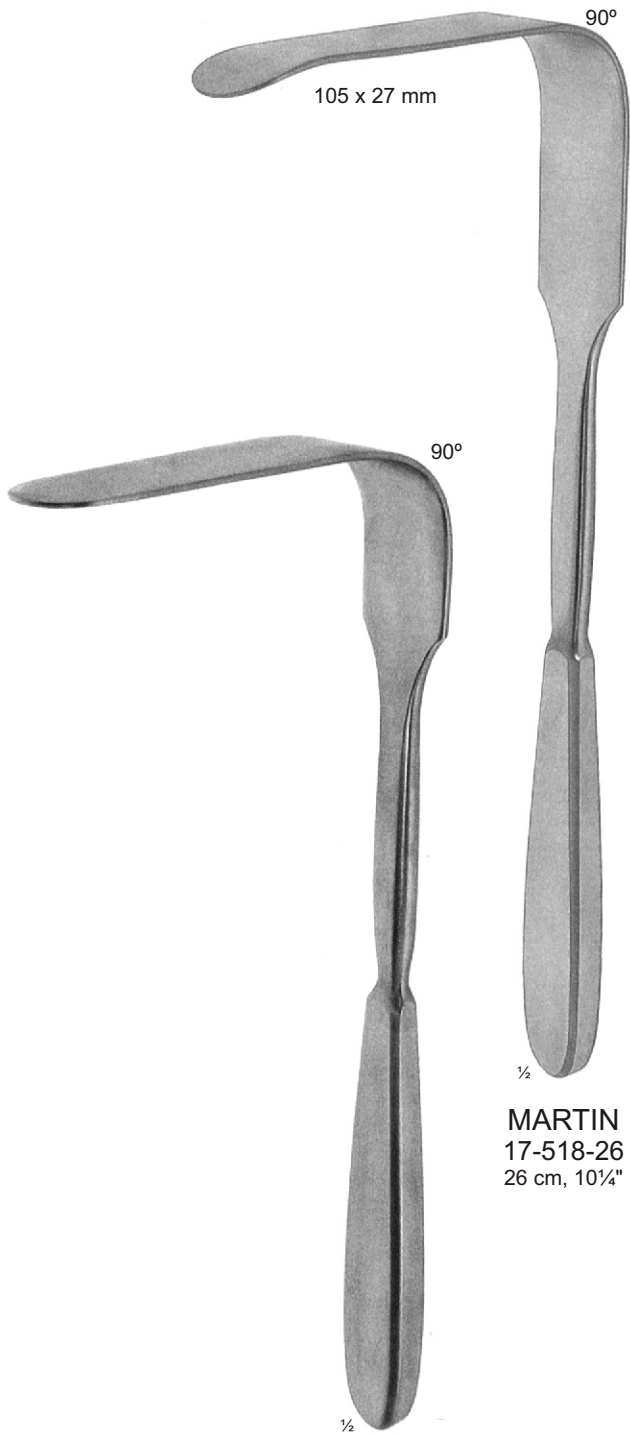

SIMON
 17-516-01 115 x 22 mm
 17-516-02 115 x 27 mm
 28 cm, 11"

MARTIN
 17-518-26
 26 cm, 10 1/4"

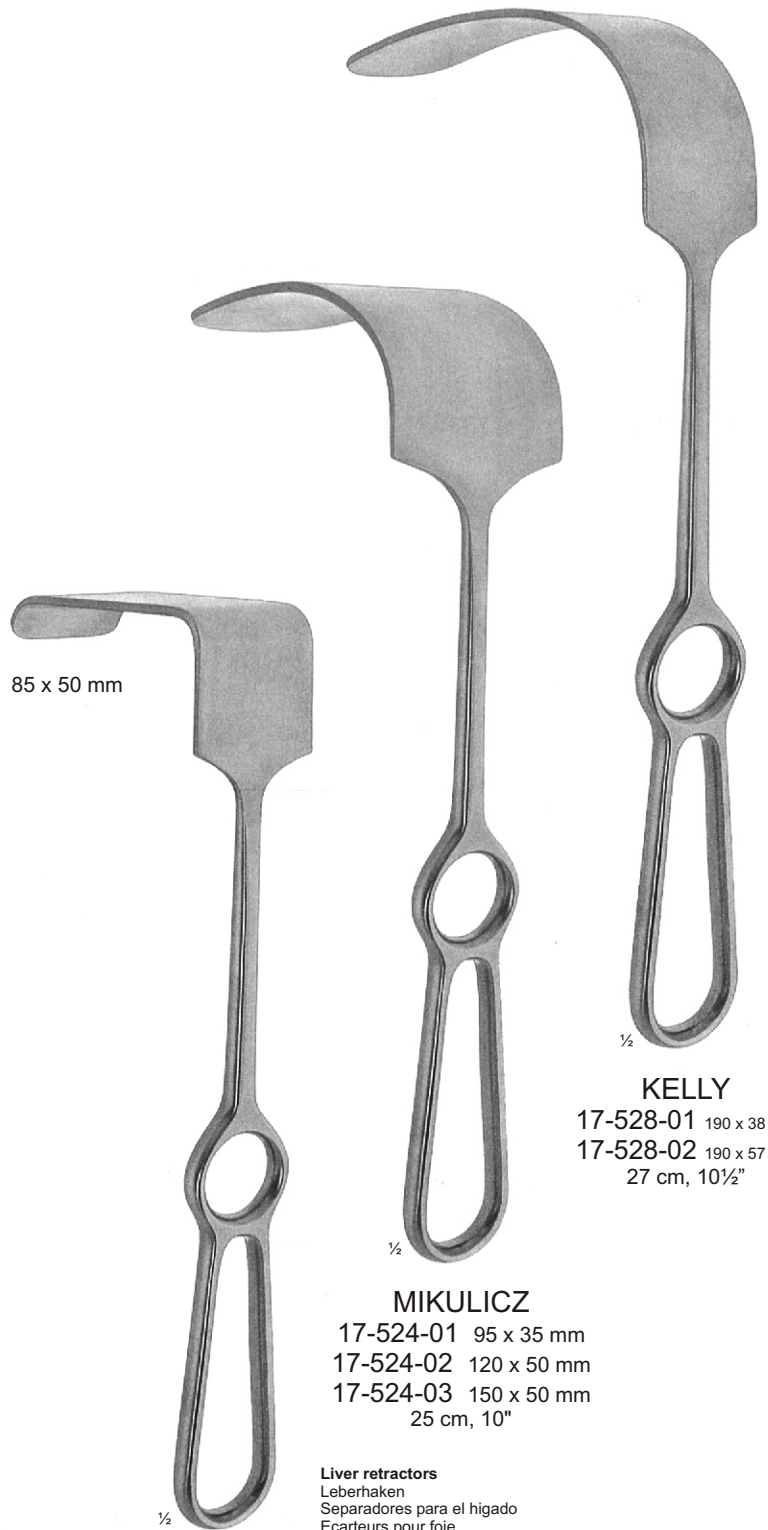

MIKULICZ
 17-522-26
 26 cm, 10 1/4"

Liver retractors
 Leberhaken
 Separadores para el higado
 Ecarteurs pour foie
 Divaricatori per fegato

MIKULICZ
 17-524-01 95 x 35 mm
 17-524-02 120 x 50 mm
 17-524-03 150 x 50 mm
 25 cm, 10"

KELLY
 17-528-01 190 x 38 mm
 17-528-02 190 x 57 mm
 27 cm, 10 1/2"



Retractors for Deep Surgery
 Wundhaken für Eingriffe in der tiefe
 Separadores para cirugía profunda
 Ecarteurs pour interventions en profondeur
 Divaricatori per interventi in profondità



017

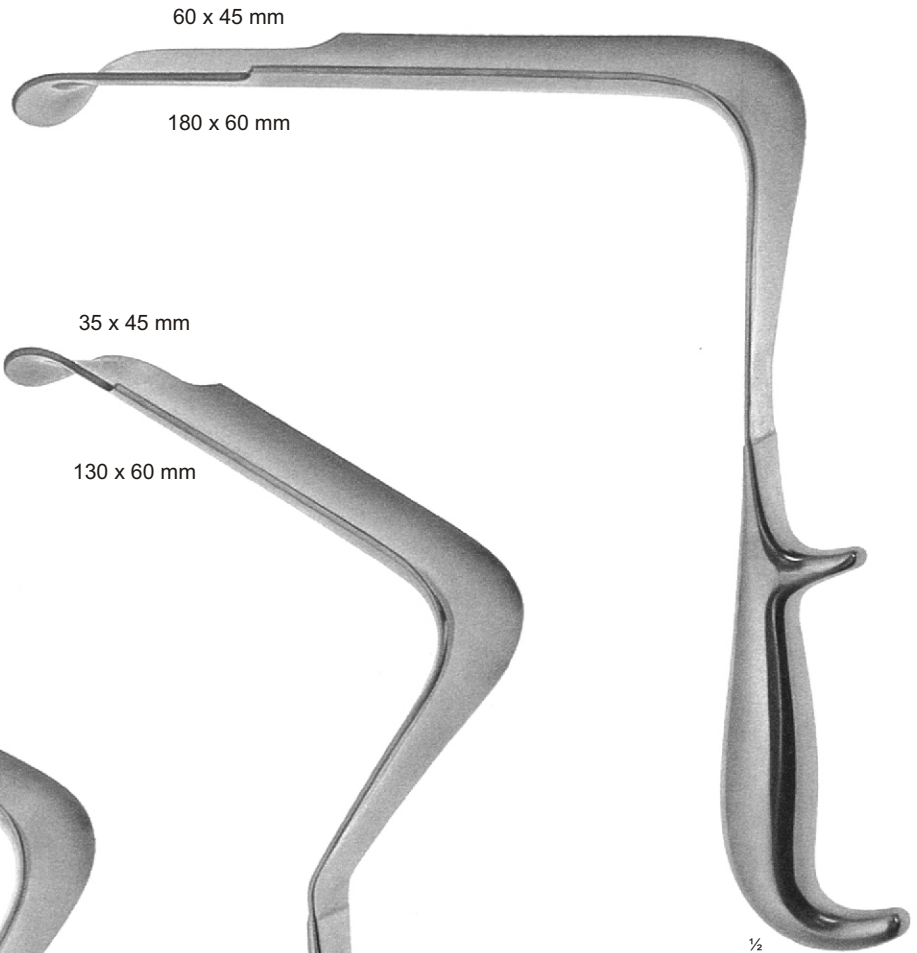

½

ST.MARKS
 17-534-33
 33 cm, 13"

Pelvis retractor
 Pelvishaken
 Separador para pelvis
 Ecarteur à pelvis
 Divaricatore per pelvis

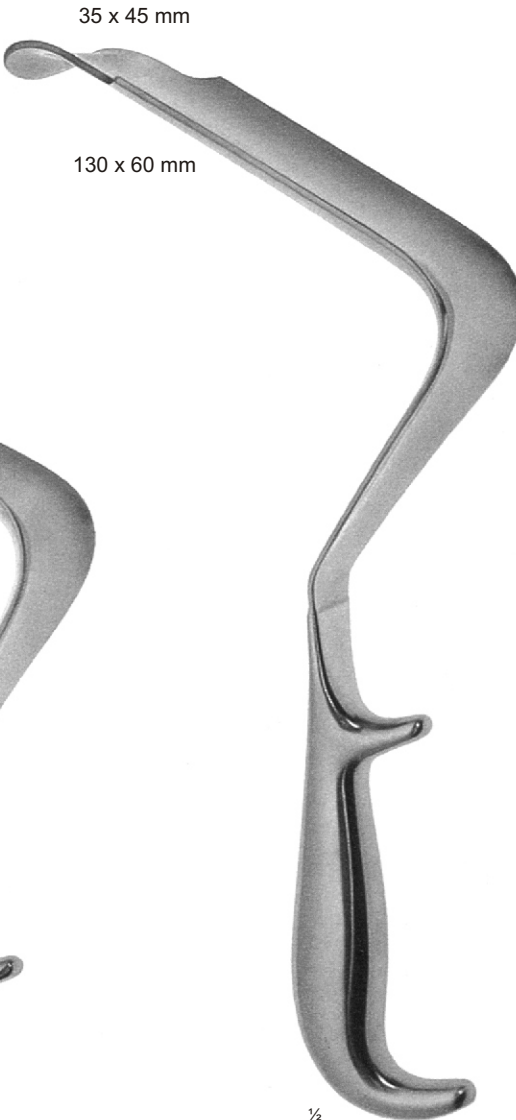

½

ST.MARKS
 17-532-29
 29 cm, 11½"

Pelvis retractor
 Pelvishaken
 Separador para pelvis
 Ecarteur à pelvis
 Divaricatore per pelvis



½

ST.MARKS
 17-530-33
 33 cm, 13"

Pelvis retractor
 Pelvishaken
 Separador para pelvis
 Ecarteur à pelvis
 Divaricatore per pelvis

Lung Retractors

Lungenhaken
Separadores para el pulmón
Ecarteur à poumons
Divaricatori per polmone

Scapula Retractors

Scapula-Haken
Separadores para scápula
Ecarteur à scapula
Divaricatori per scapola

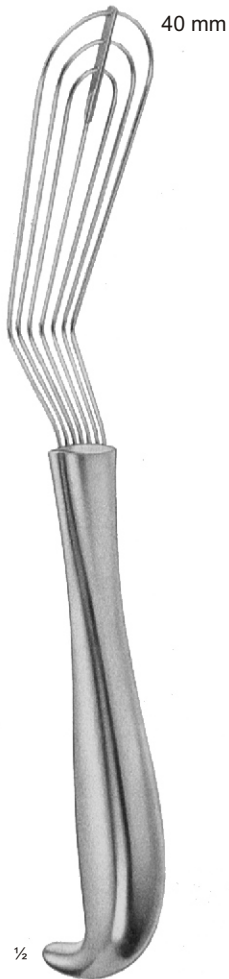

ALLISON
17-540-25
25 cm, 10"

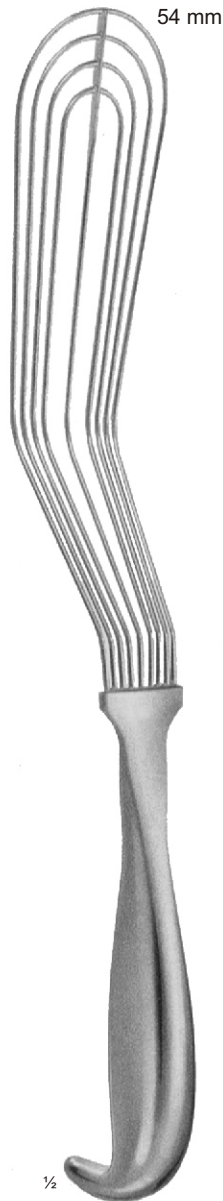

ALLISON
17-542-32
32 cm, 12 1/2"

Lung spatula
Lungenspatel
Espátula para el pulmón
Spatule pulmonaire
Spatole per polmone



DAVIDSON
17-546-16
16 cm, 6 1/4"

Scapula retractor
Scapula-Haken
Separador para Scápula
Ecarteur à scapula
Dicaricatore per scapola



DAVIDSON
17-548-16
16 cm, 6 1/4"

Scapula retractor
Scapula-Haken
Separador para Scápula
Ecarteur à scapula
Dicaricatore per scapola

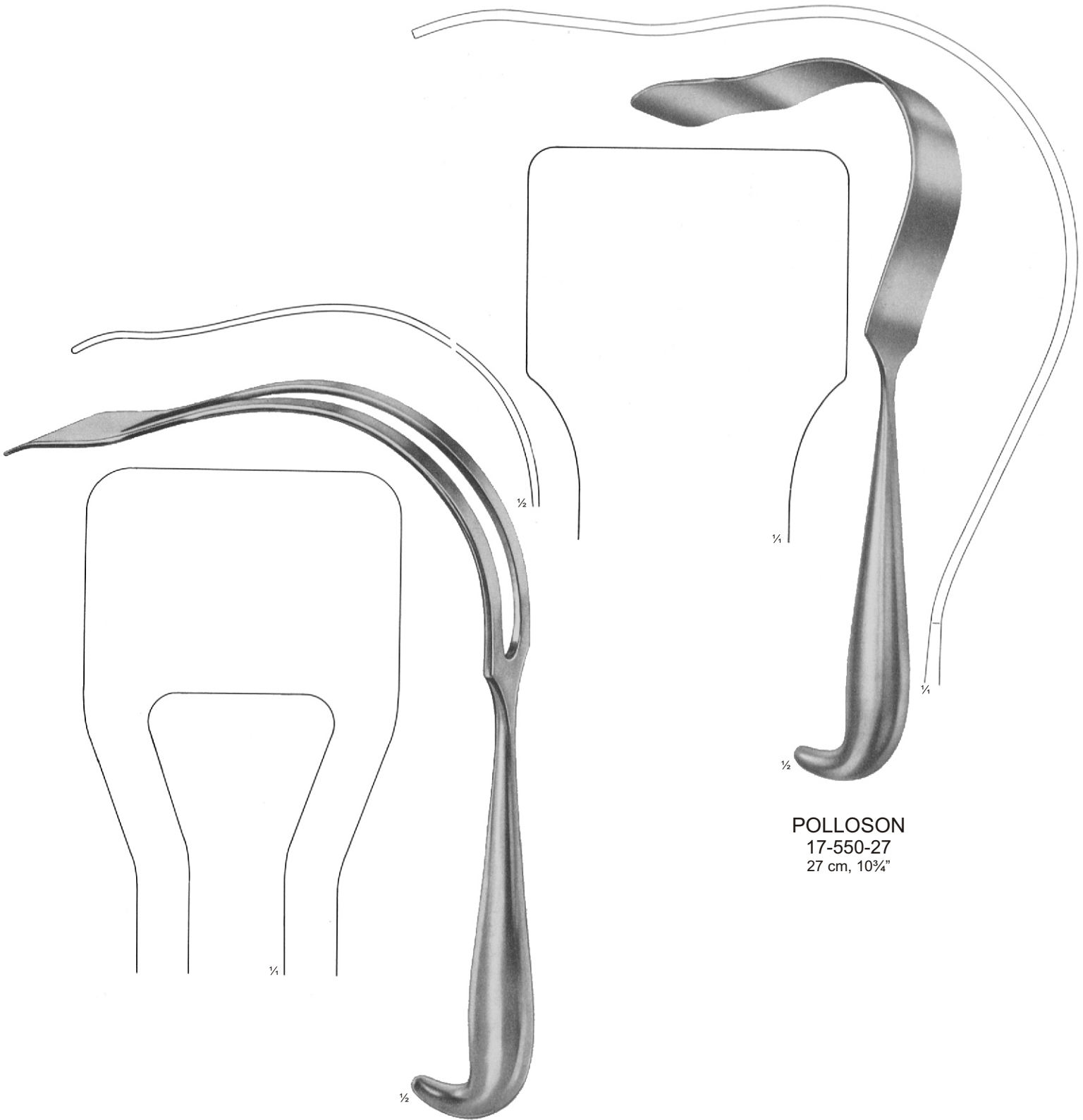

POLLOSON
 17-550-26
 26 cm, 10¼"

POLLOSON
 17-550-27
 27 cm, 10¾"

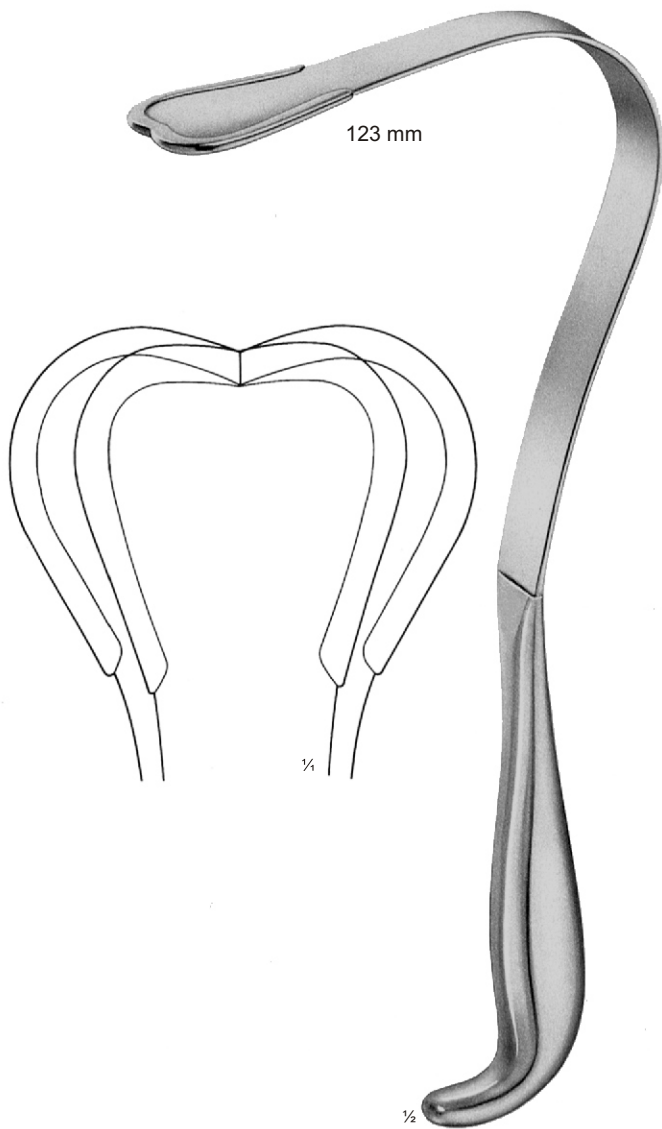

HARRINGTON
 17-560-01 127 x 40 mm
 17-562-02 127 x 62 mm
 32 cm, 12½"

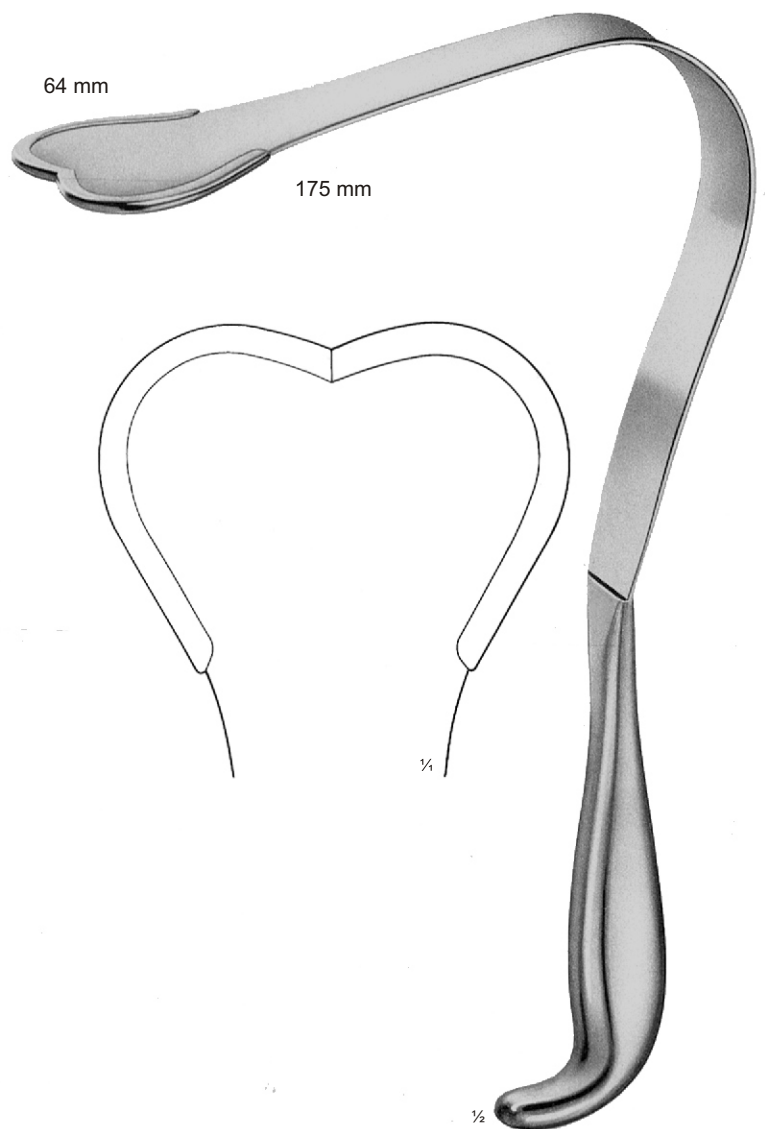

HARRINGTON-PEMBERTON
 17-562-29
 175 x 64 mm
 29,5 cm, 11¼"



19 mm



1/4

DEAVER
 17-570-01
 18 cm, 7"

22 mm



1/4

DEAVER
 17-570-02
 21,5 cm, 8½"

25 mm

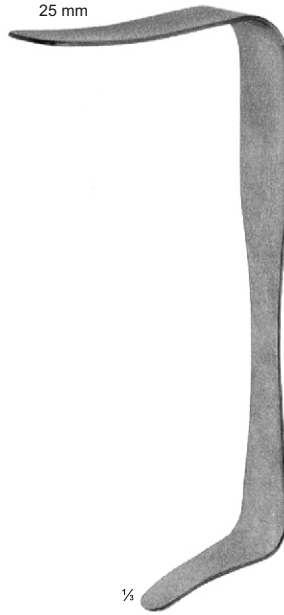

1/4

DEAVER
 17-570-03
 23 cm, 9"

25 mm



1/4

DEAVER
 17-570-04
 30 cm, 12"

25 mm



1/4

DEAVER
 17-570-05
 30 cm, 12"

25 mm



1/4

DEAVER
 17-570-06
 33 cm, 13"

25 mm

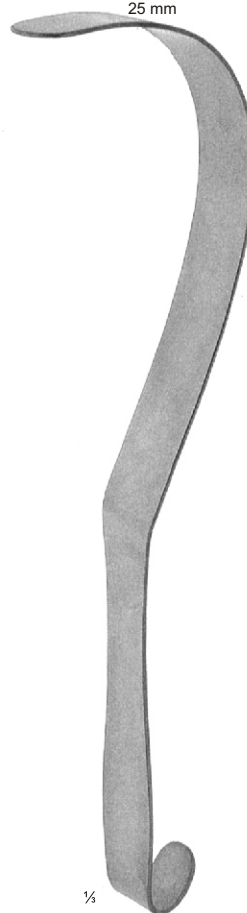

1/4

DEAVER
 17-570-07
 36 cm, 14"

38 mm



1/4

DEAVER
 17-570-08
 30 cm, 12"



50 mm

DEAVER
 17-570-09
 30 cm, 12"



25 mm

17-580-01
 31 cm, 12¼"



38 mm

17-580-02
 31 cm, 2¼"

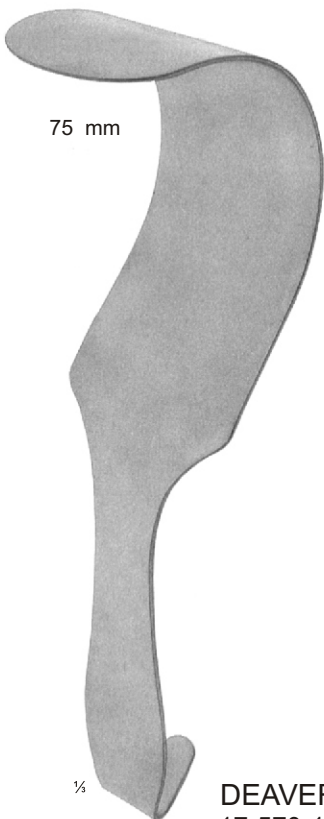

75 mm

DEAVER
 17-570-10
 30 cm, 12"



DEAVER
 17-580-01
 17-580-04



50 mm

17-580-03
 30,5 cm, 12"



75 mm

17-580-04 17-580-05
 31 cm, 12¼" 31 cm, 12¼"

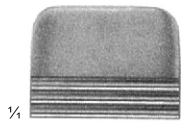

17-600-01
20 mm

17-600-02
30 mm

17-600-03
40 mm



KADER
 17-600-01
 17-600-03
 27,5 cm, 10¾"



17-610-06
20cm x 6,5 mm
 17-610-09
20cm x 9,5 mm
 17-610-13
20cm x 13 mm
 17-610-16
20cm x 16 mm
 17-610-19
20cm x 19 mm
 17-610-25
20cm x 25 mm

17cm x 6¾"

17 x 25 mm



TUFFIER
 17-614-01
 20 cm, 8"

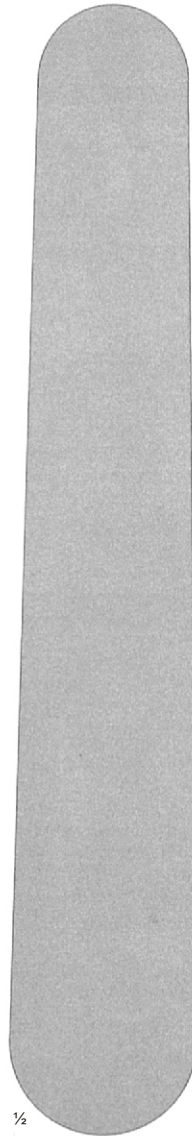

HÄBERER
 17-618-01 17 x 25 mm
 20 cm, 8"
 17-618-02 25 x 30 mm
 28 cm, 11"
 17-618-03 37 x 45 mm
 30 cm, 12"



17-622-01 330 x 20 mm
 17-622-02 330 x 25 mm
 17-622-03 330 x 30 mm
 17-622-04 330 x 35 mm
 17-622-05 330 x 40 mm
 17-622-06 330 x 45 mm
 17-622-07 330 x 50 mm

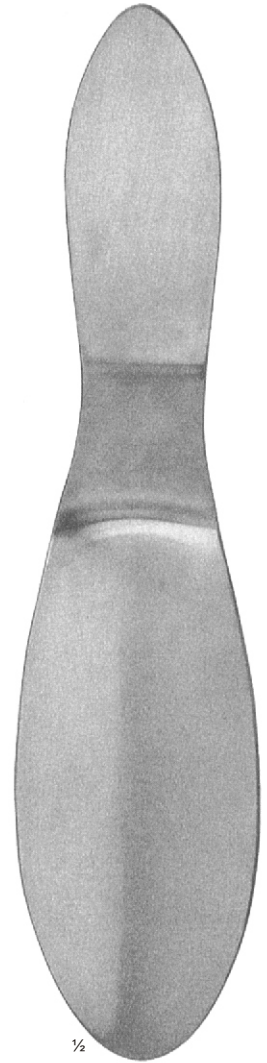

REVERDIN
 17-628-01
 28 cm, 11"

← Malleable, Biegsam, Maleable, Malléable, Malleabile →