

017



**Self-Retaining Retractors, Abdominal Retractors**  
**Wundspreizer (selbsthaltend), Bauchdeckenhalter**  
**Separadores con retenida automática, Separadores abdominales**  
**Ecarteurs autostatiques, Ecarteurs abdominaux**  
**Divaricatori autostatici, Divaricatori addominali**



**Self-Retaining Retractors**  
 Wundspreizer, selbsthaltend  
 Separadores con retenida automática  
 Ecarteurs autostatiques  
 Divaricatori autostatici

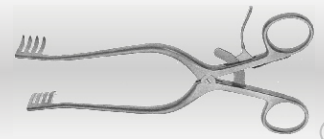

017

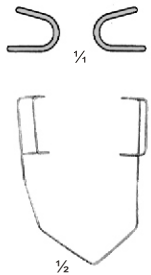

**BARRAQUER**  
 17-640-04  
 4,5 cm, 1¾"



**SAUER**  
 17-644-03  
 3,5 cm, 1¼"

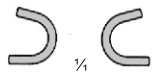

**LANCASTER**  
 17-648-08  
 8 cm, 3⅞"



**MELLINGER**  
 17-650-01  
 17-650-03  
 7 cm, 2¾"

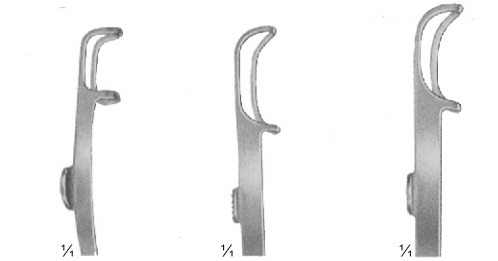

17-650-01      17-650-02      17-650-03

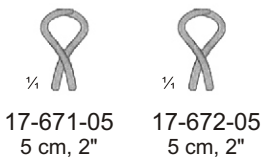

17-671-05      17-672-05  
 5 cm, 2"      5 cm, 2"



17-671-07      17-672-07  
 7 cm, 2¾"      7 cm, 2¾"

**Sharp**  
 Spitz  
 Agudo  
 Pointu  
 Acuto

**Blunt**  
 Stumpf  
 Romo  
 Mousse  
 Smusso



**FINSEN**  
 17-671-05  
 17-672-07

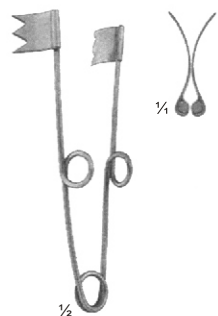

17-654-08  
 8,5 cm, 3¼"  
 17-654-11  
 11,5 cm, 4½"

**Self-retaining retractor**  
 Wundspreizer, selbsthaltend  
 Separador con retenida automática  
 Ecarteur autostatiques  
 Divaricatori autostatici



17-656-04  
 4,5 cm, 1¾"



17-658-05  
 5,5 cm, 2"



**MUELLER**  
 17-662-06  
 6,5 cm, 2½"



**LOGAN**  
 17-666-04  
 4,5 cm, 1½"

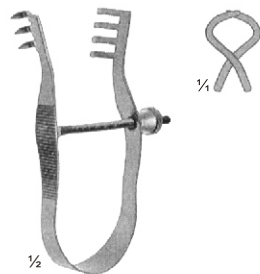

**FINSEN**  
 17-675-07      17-676-07  
 7 cm, 2¾"      7 cm, 2¾"

**Sharp**  
 Spitz  
 Agudo  
 Pointu  
 Acuto

**Blunt**  
 Stumpf  
 Romo  
 Mousse  
 Smusso

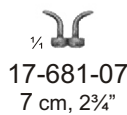

17-681-07  
 7 cm, 2¾"

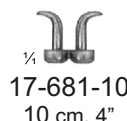

17-681-10  
 10 cm, 4"

**Sharp**  
 Spitz  
 Agudo  
 Pointu  
 Acuto

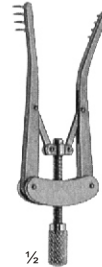

**ALM**  
 17-681-07  
 17-682-10

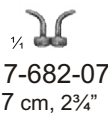

17-682-07  
 7 cm, 2¾"

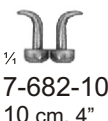

17-682-10  
 10 cm, 4"

**Blunt**  
 Stumpf  
 Romo  
 Mousse  
 Smusso

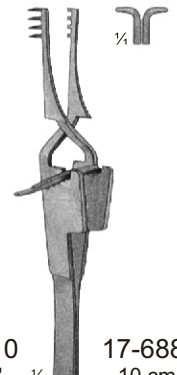

17-687-10      17-688-10  
 10 cm, 4"      10 cm, 4"

**Sharp**  
 Spitz  
 Agudo  
 Pointu  
 Acuto

**Blunt**  
 Stumpf  
 Romo  
 Mousse  
 Smusso

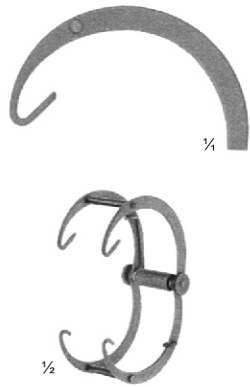
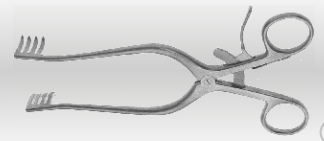

**VICKERS**  
 17-710-04  
 4,5 cm, 1¾"

**Finger retractor**  
 Finger-Wundspreizer  
 Separador para dedos  
 Ecarteur pour doigts  
 Divaricatore per dita



**VICKERS**  
 17-702-09  
 9 cm, 3½"

**Hand and carpal tunnel retractor,**  
 with central valve 18 x 10mm (17-710-09)

Hand- und Carpal-Tunnel-Wundspreizer,  
 mit Mittelvalve 18x10 mm (17-710-09)

Separador de mano y túnel de carpo,  
 con valva central 18x10 mm (17-710-09)

Ecarteur pour mains et tunnel carpien,  
 avec valve médiane 18x10 mm (17-710-09)

Divaricatore per la mano con condotto carpale,  
 con valva centrale 18x10 mm (17-710-09)



**VICKERS**  
 17-704-10  
 10 cm, 4"

**Deep hand and forearm retractor,**  
 with central valve 18x10 mm (17-712-09)

Hand- und Unterarm-Wundspreizer,  
 mit Mittelvalve 18x10 mm (17-712-09)

Separador profundo para mano y antebrazo,  
 con valva central 18x10 mm (17-712-09)

Ecarteur profond pour main et avant bras,  
 avec valve médiane 18x10 mm (17-712-09)

Divaricatore per la mano e l'avambraccio,  
 con valva centrale 18x10 mm (17-712-09)



**VICKERS**  
 17-706-08  
 8 cm, 3¼"

**Trigger finger and small wound retractor,**  
 with central valve 18x10 mm (17-716-08)

Schnellender Finger- und kleiner Schnitt-Wund- spreizer,  
 mit Mittelvalve 18x10 mm (17-716-08)

Separador para dedos y pequeñas heridas,  
 con valva central 18x10 mm (17-716-08)

Ecarteur pour doigts et petites plaies,  
 avec valve médiane 18x10 mm (17-716-08)

Impugnatura a molla per dita e piccolo divaricatore per ferite,  
 con valva centrale 18x10 mm (17-716-08)



**17-721-10**  
 10 cm, 4"

**Sharp**  
 Spitz  
 Agudo  
 Pointu  
 Acuto

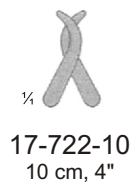

**17-722-10**  
 10 cm, 4"

**Blunt**  
 Stumpf  
 Romo  
 Mousse  
 Smusso

**JANSEN**  
 17-721-10  
 17-722-10

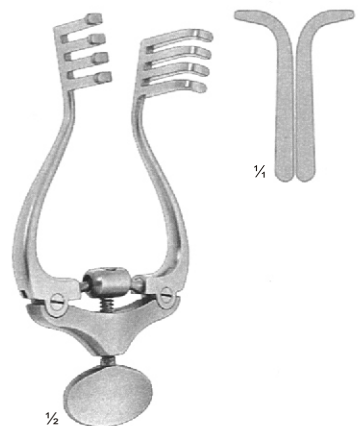

**JANSEN**  
 17-724-11  
 11 cm, 4¾"

**Blunt**  
 Stumpf  
 Romo  
 Mousse  
 Smusso

### Self-Retaining Retractors

Wundspreizer, selbsthaltend  
 Separadores con retenida automática  
 Ecarteurs autostatiques  
 Divaricatori autostatici

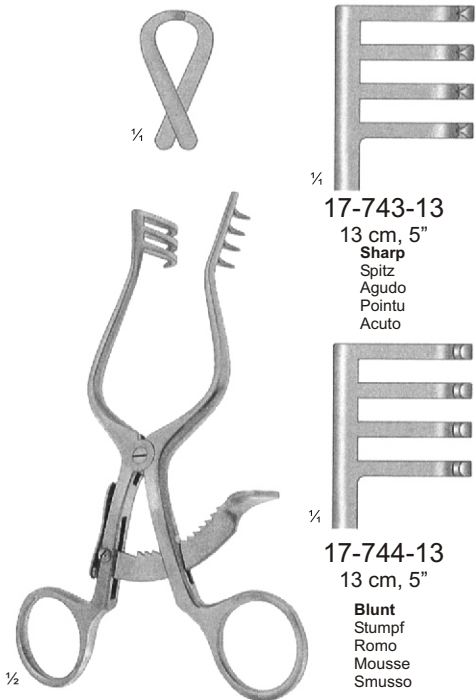
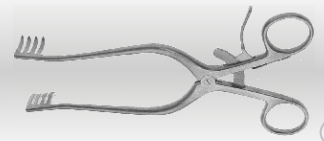

17-743-13

13 cm, 5"  
**Sharp**  
 Spitz  
 Agudo  
 Pointu  
 Acuto

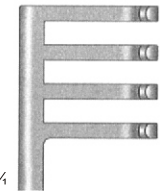

17-744-13

13 cm, 5"  
**Blunt**  
 Stumpf  
 Romo  
 Mousse  
 Smusso

#### WULLSTEIN

17-743-13  
 17-744-13

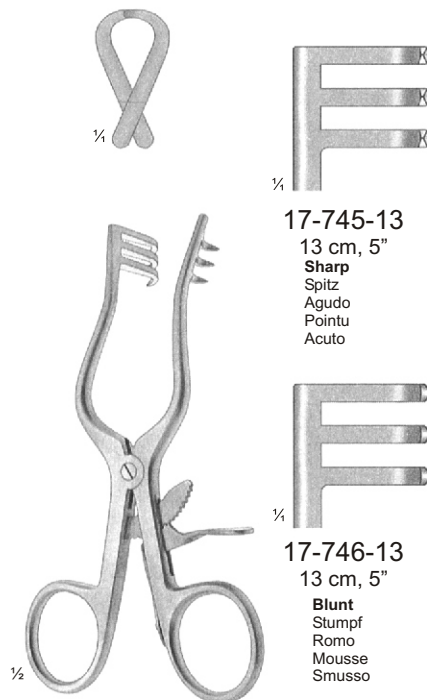

17-745-13

13 cm, 5"  
**Sharp**  
 Spitz  
 Agudo  
 Pointu  
 Acuto

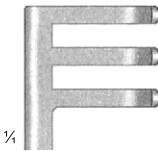

17-746-13

13 cm, 5"  
**Blunt**  
 Stumpf  
 Romo  
 Mousse  
 Smusso

#### WETLANER-WULLSTEIN

17-745-13  
 17-746-13

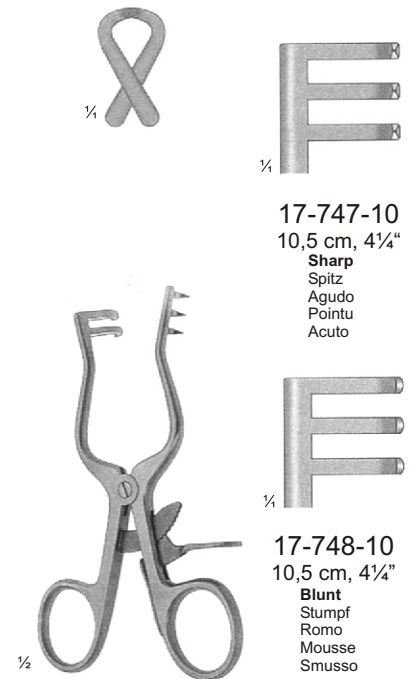

17-747-10

10,5 cm, 4¼"  
**Sharp**  
 Spitz  
 Agudo  
 Pointu  
 Acuto

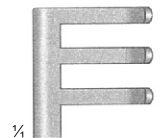

17-748-10

10,5 cm, 4¼"  
**Blunt**  
 Stumpf  
 Romo  
 Mousse  
 Smusso

#### WEITLANER-LOKTITE

17-747-10  
 17-748-10

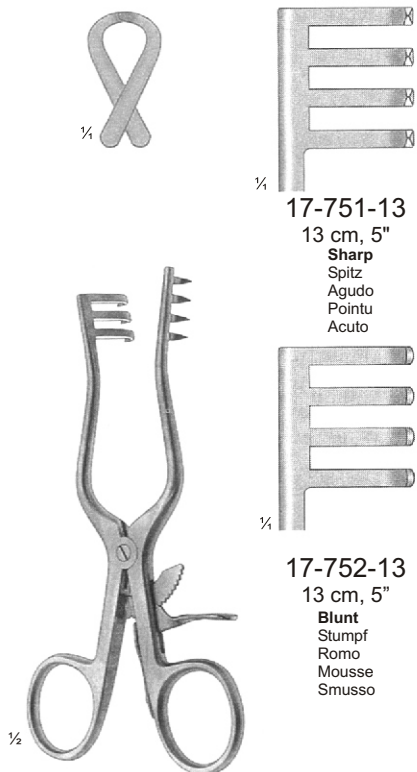

17-751-13

13 cm, 5"  
**Sharp**  
 Spitz  
 Agudo  
 Pointu  
 Acuto

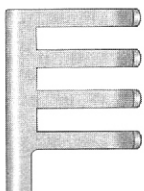

17-752-13

13 cm, 5"  
**Blunt**  
 Stumpf  
 Romo  
 Mousse  
 Smusso

#### WEITLANER

17-751-13  
 17-752-13

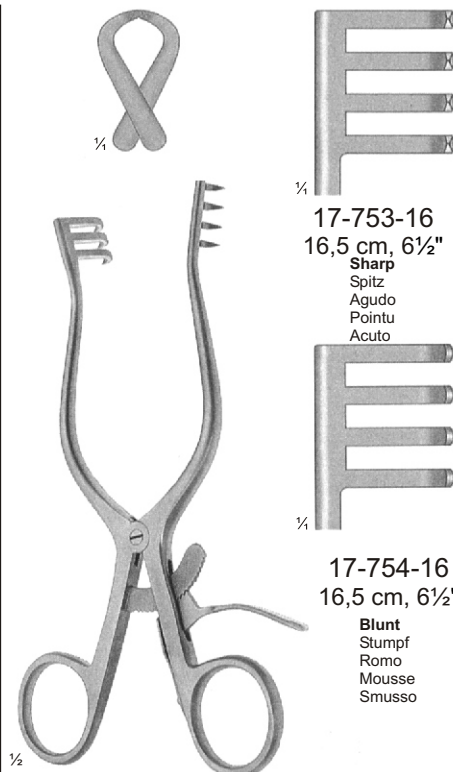

17-753-16

16,5 cm, 6½"  
**Sharp**  
 Spitz  
 Agudo  
 Pointu  
 Acuto

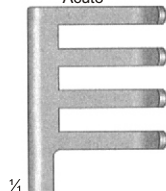

17-754-16

16,5 cm, 6½"  
**Blunt**  
 Stumpf  
 Romo  
 Mousse  
 Smusso

#### WEITLANER

17-753-16  
 17-754-16

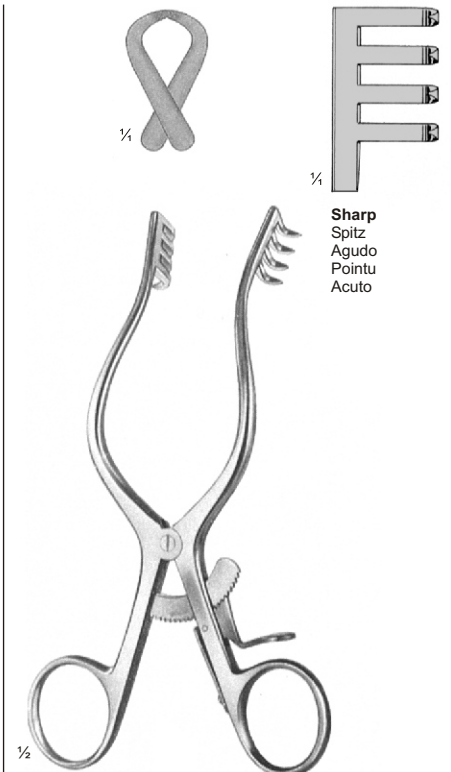

**Sharp**  
 Spitz  
 Agudo  
 Pointu  
 Acuto

#### MOLLISON

17-757-15  
 15 cm, 6"

### Self-Retaining Retractors

Wundspreizer, selbsthaltend  
 Separadores con retenida automática  
 Ecarteurs autostatiques  
 Divaricatori autostatici

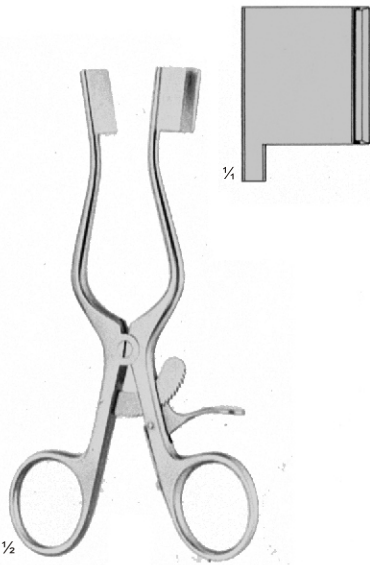
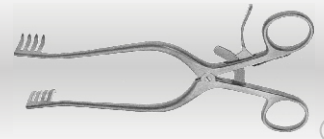

**WEITLANER-BABY**  
 17-770-13  
 13 cm, 5"

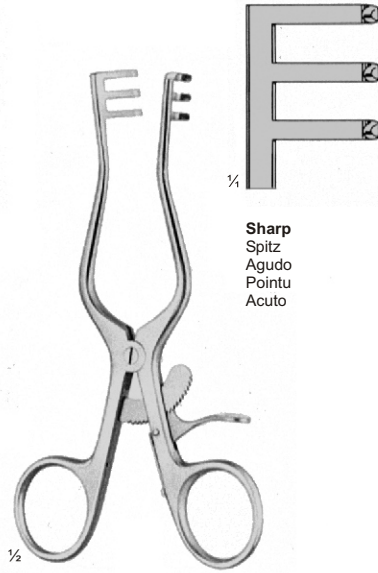

**MILLIGAN**  
 17-773-13  
 17-474-13  
 13 cm, 5"

**Sharp**  
 Spitz  
 Agudo  
 Pointu  
 Acuto

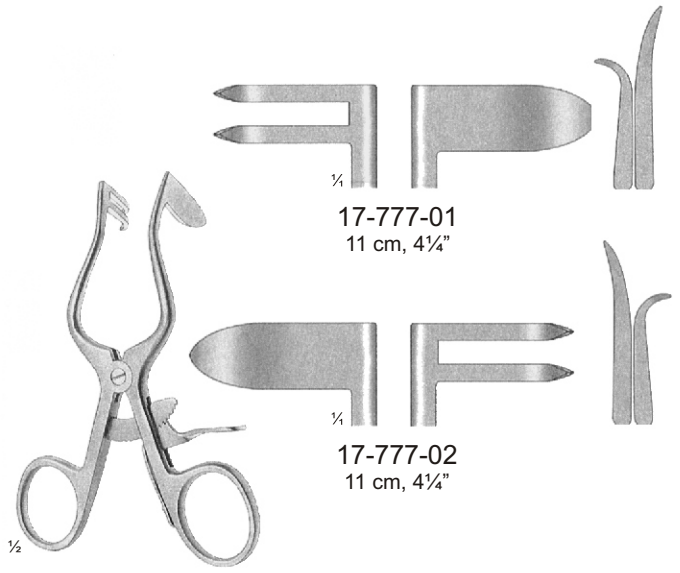

**PLESTER**  
 17-777-01  
 17-777-02

17-777-01  
 11 cm, 4 1/4"

17-777-02  
 11 cm, 4 1/4"

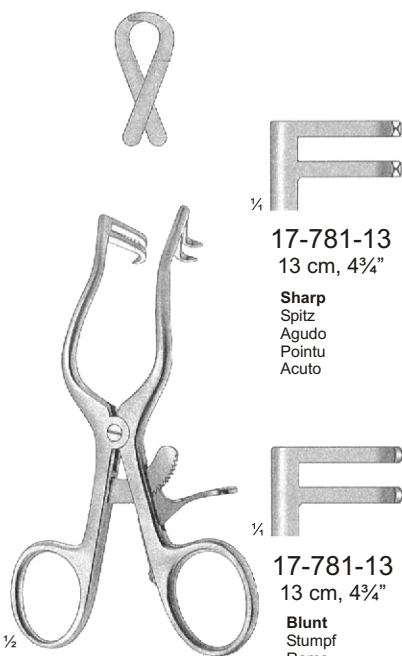

**PLESTER**  
 17-781-13  
 17-781-13  
 13 cm, 4 3/4"

17-781-13  
 13 cm, 4 3/4"

**Sharp**  
 Spitz  
 Agudo  
 Pointu  
 Acuto

17-781-13  
 13 cm, 4 3/4"

**Blunt**  
 Stumpf  
 Romo  
 Mousse  
 Smusso

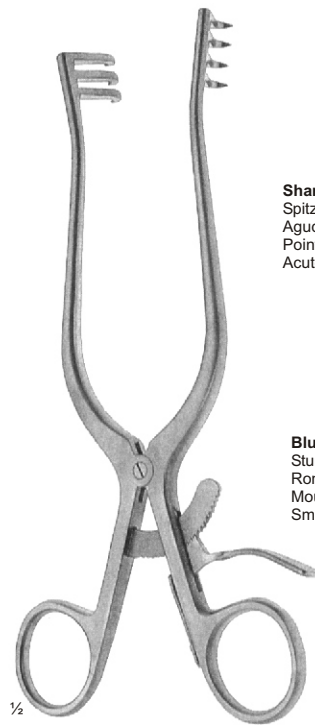

**WEITLANER**  
 17-785-01  
 17-786-03

**Sharp**  
 Spitz  
 Agudo  
 Pointu  
 Acuto

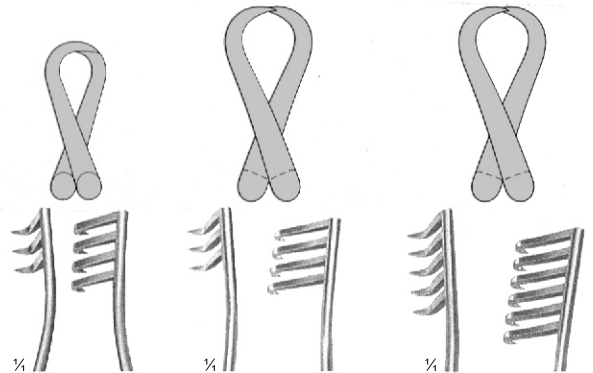

17-785-01  
 20 cm, 8"

17-785-02  
 24 cm, 9 1/4"

17-785-03  
 25,5 cm, 10"

**Blunt**  
 Stumpf  
 Romo  
 Mousse  
 Smusso

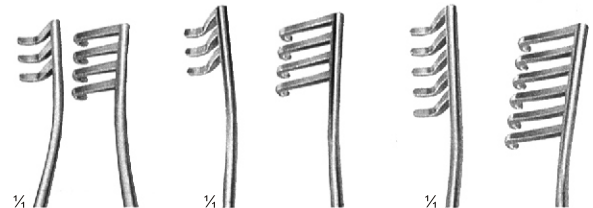

17-786-01  
 20 cm, 8"

17-786-02  
 24 cm, 9 1/4"

17-786-03  
 25,5 cm, 10"

**Retractors**

Self-Retaining Retractors  
 Separadores con retenida automática  
 Ecarteurs autostatiques  
 Divaricatori autostatici

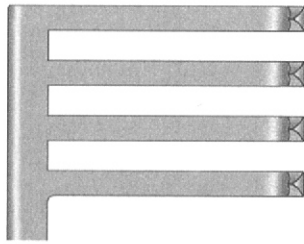
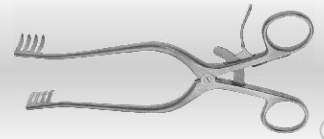

¼

**Sharp**  
 Spitz  
 Agudo  
 Pointu  
 Acuto

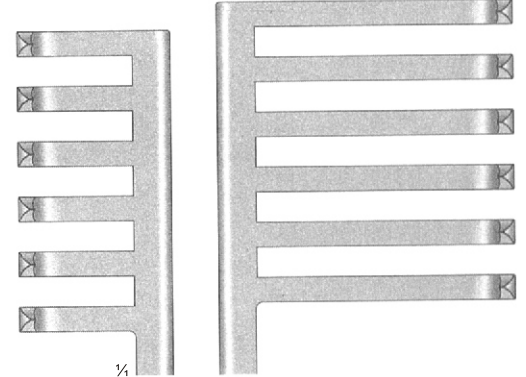
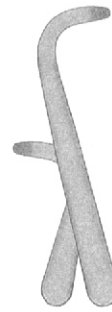

¼

17-795-27

**Sharp**  
 Spitz  
 Agudo  
 Pointu  
 Acuto

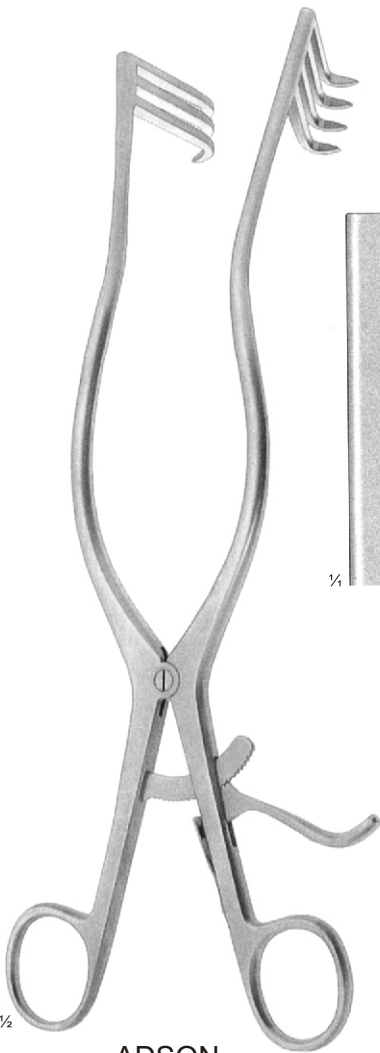

½

**ADSON**

17-791-26  
 17-792-26  
 17-793-26  
 17-794-26  
 26,5 cm, 10½"

**Laminectomy retractor**  
 Laminektomie- Wundspreizer  
 Separador para laminectomia  
 Ecarteurs pour laminectomie  
 Divaricatori per laminectomia

¼

**Blunt**  
 Stumpf  
 Romo  
 Mousse  
 Smusso

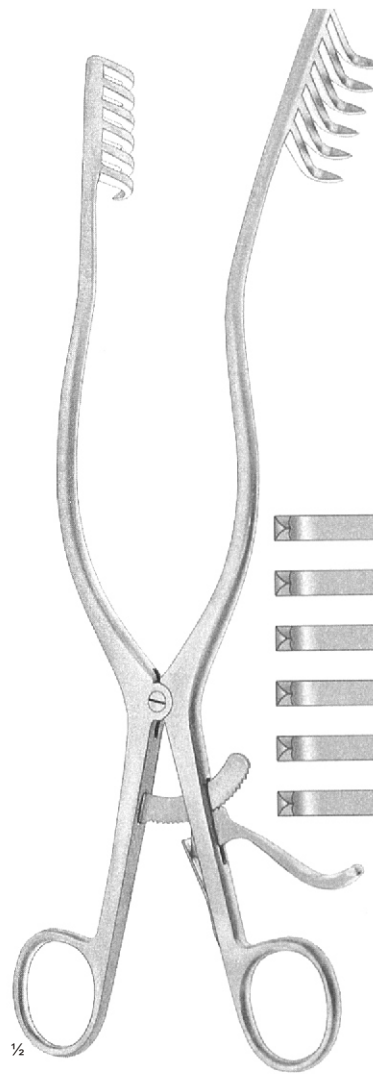

½

**ADSON**

17-795-27  
 17-797-27  
 27 cm, 10½"

¼

17-797-27

**Blunt**  
 Stumpf  
 Romo  
 Mousse  
 Smusso

### Self-Retaining Retractors

Wundspreizer, selbsthaltend  
 Separadores con retenida automática  
 Ecarteurs autostatiques  
 Divaricatori autostatici

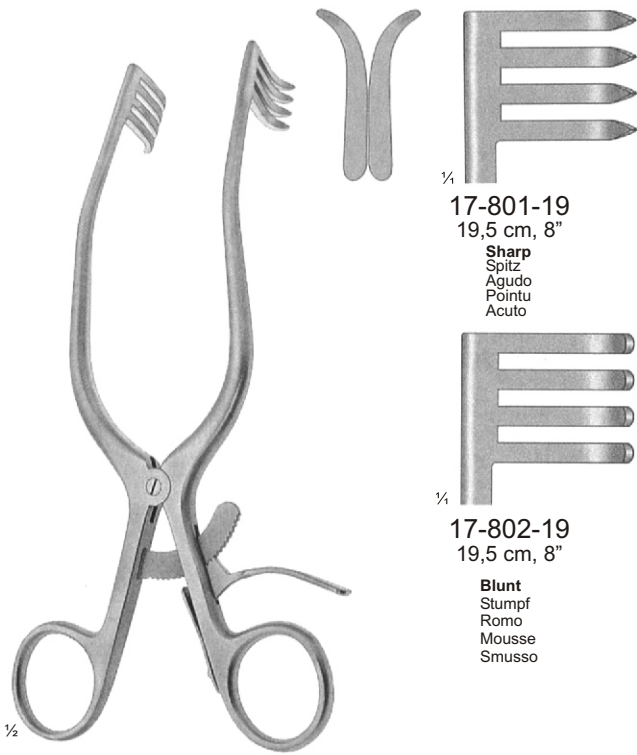
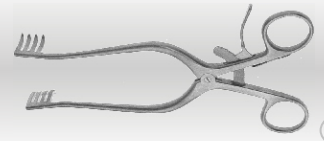

17-801-19  
 19,5 cm, 8"  
**Sharp**  
 Spitz  
 Agudo  
 Pointu  
 Acuto

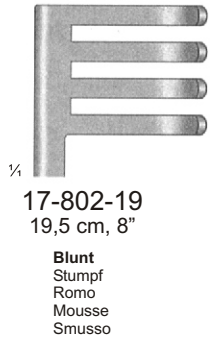

**ANDERSON-ADSON**  
 17-801-19



17-803-20  
 20 cm, 8"  
**Sharp**  
 Spitz  
 Agudo  
 Pointu  
 Acuto

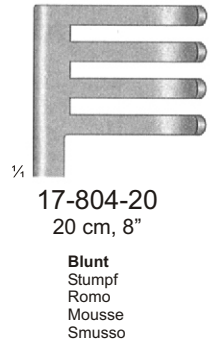

**ADSON**  
 17-803-20  
 17-804-20



**Sharp**  
 Spitz  
 Agudo  
 Pointu  
 Acuto

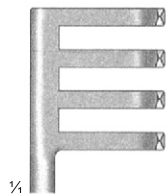

17-805-13  
 13 cm, 5"

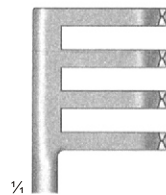

17-805-16  
 16 cm, 6 1/4"

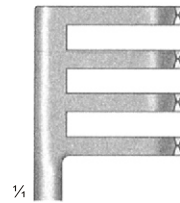

17-805-20  
 20 cm, 8"

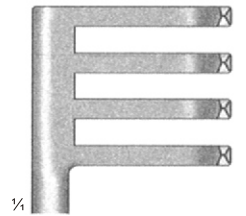

17-805-26  
 26 cm, 10 1/4"

**Blunt**  
 Stumpf  
 Romo  
 Mousse  
 Smusso

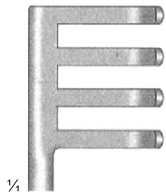

17-806-13  
 13 cm, 5"

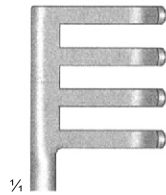

17-806-16  
 16 cm, 6 1/4"

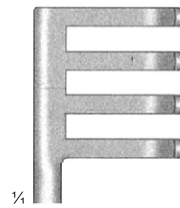

17-806-20  
 20 cm, 8"

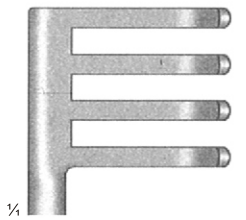

17-806-26  
 26 cm, 10 1/4"

**ADSON**  
 17-805-13  
 17-806-26

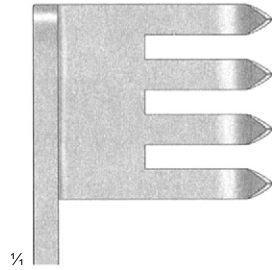
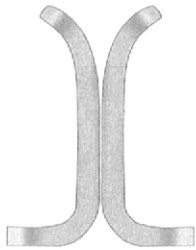
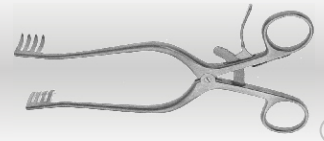

1/4  
**17-811-01**  
 Sharp  
 Spitz  
 Agudo  
 Pointu  
 Acuto

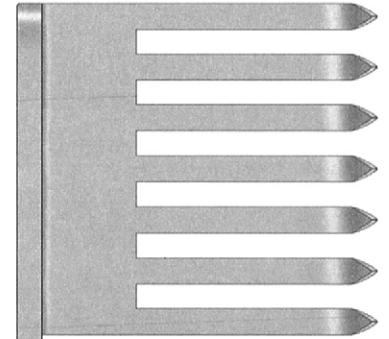

**Sharp**  
 Spitz  
 Agudo  
 Pointu  
 Acuto

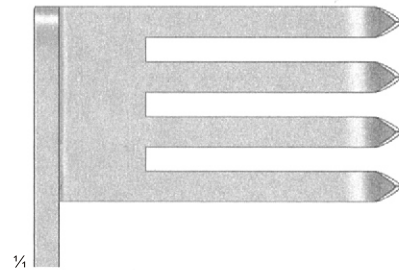
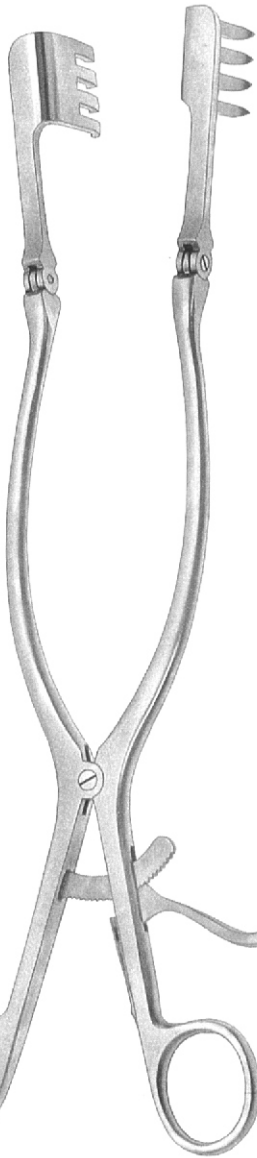

1/4  
**17-811-02**  
 Sharp  
 Spitz  
 Agudo  
 Pointu  
 Acuto

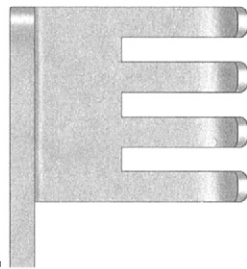

1/4  
**17-812-01**  
 Blunt  
 Stumpf  
 Romo  
 Mousse  
 Smusso

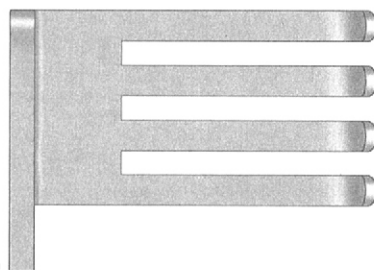

1/4  
**17-812-02**  
 Blunt  
 Stumpf  
 Romo  
 Mousse  
 Smusso

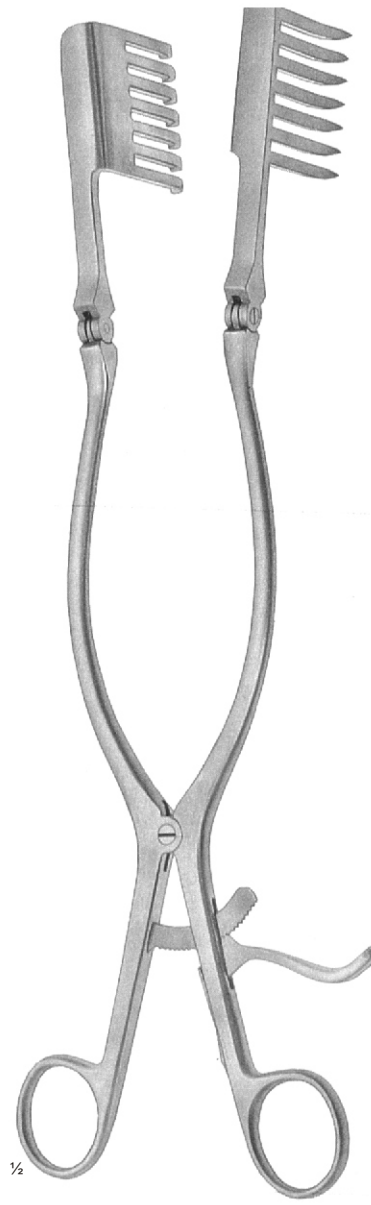

**BECKMANN-EATON**  
 17-815-32  
 32 cm, 12 1/2"

**BECKMANN-ADSON**  
 17-811-01  
 17-811-02  
 31 cm, 12 1/4"

**17-812-01**  
**17-812-02**  
 31 cm, 12 1/4"



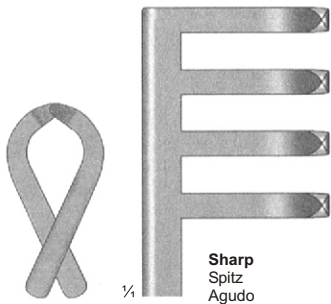
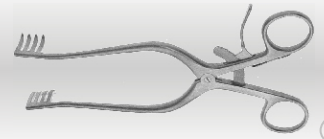

**Sharp**  
 Spitz  
 Agudo  
 Pointu  
 Acuto

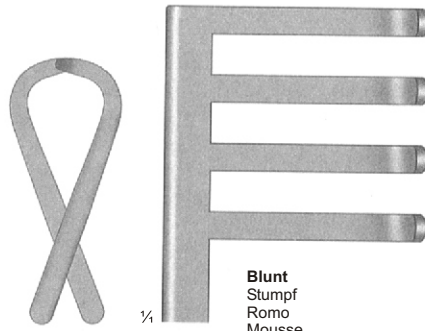

**Blunt**  
 Stumpf  
 Romo  
 Mousse  
 Smusso

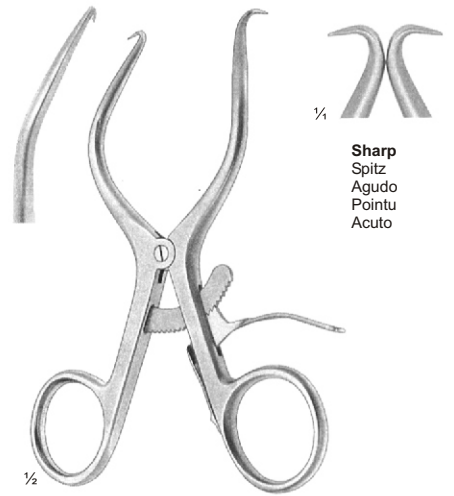

**Sharp**  
 Spitz  
 Agudo  
 Pointu  
 Acuto

**GELPI-LOKTILE**  
 17-825-13  
 13 cm, 5"

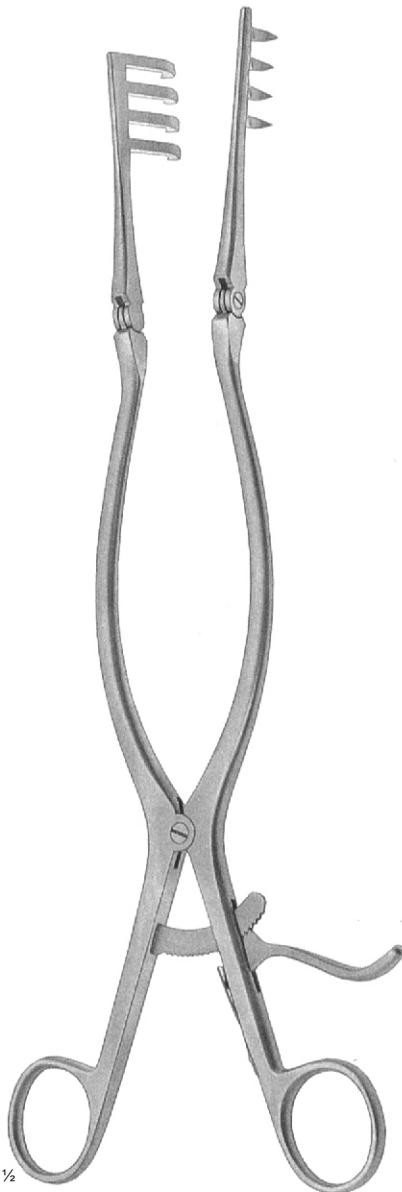

**BECKMANN**  
 17-817-31  
 31 cm, 12 1/4"



**ADSON**  
 17-820-32  
 32 cm, 12 1/2"



**GELPI-LOKTIE**  
**Sharp**  
 Spitz  
 Agudo  
 Pointu  
 Acuto

17-827-09  
 9 cm, 3 1/2"  
 17-827-11  
 11 cm, 4 1/2"  
 17-827-13  
 13 cm, 5"  
 17-827-18  
 18 cm, 7"

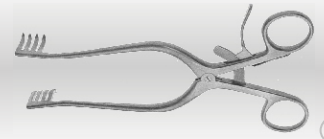

**GELPI-SEIETZ**  
 17-831-15  
 15 cm, 6"

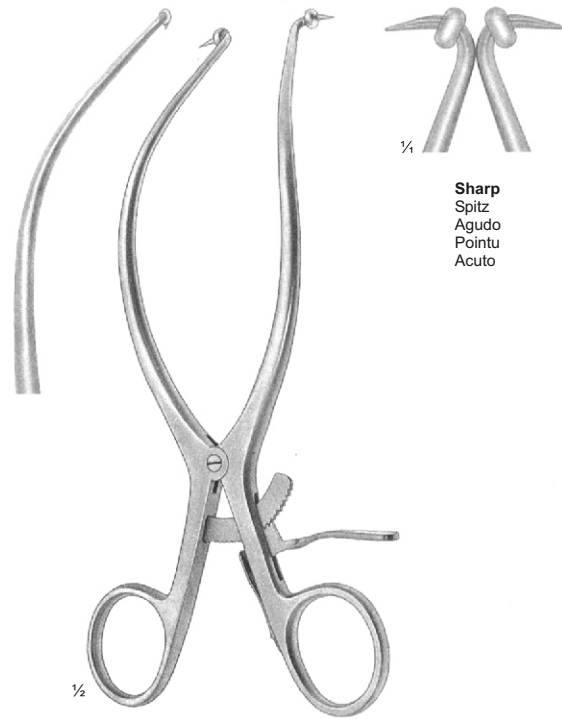

**GELPI-LOKTITE**  
 17-833-18  
 18 cm, 7"



**JOLL(FRIEDMAN)**  
 17-837-15  
 15,5 cm, 6"

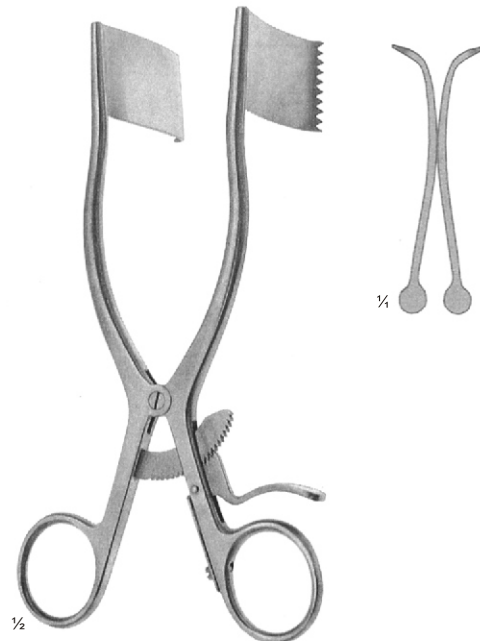

**MEYERDING**  
 17-839-01  
 17-839-02  
 17-839-03  
 17-839-04  
 18 cm, 7"

**Lamectomy retractors**  
 Laminektomie-Wundspreizer  
 Separadores para laminectomia  
 Ecarteurs pour laminectomie  
 Divaricatori per laminectomia

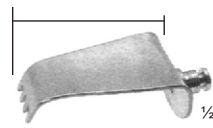
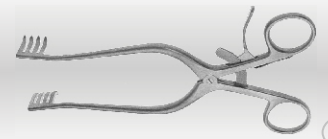

**17-841-01**  
40 x 15 - 23 mm



**17-841-02**  
45 x 15 - 23 mm



**17-841-03**  
50 x 15 - 23 mm

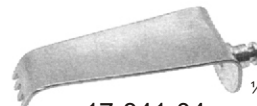

**17-841-04**  
55 x 15 - 23 mm



**17-841-05**  
60 x 15 - 23 mm

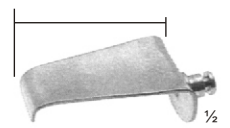

**17-842-01**  
40 x 15 - 23 mm



**17-842-02**  
45 x 15 - 23 mm



**17-842-03**  
50 x 15 - 23 mm



**17-842-04**  
55 x 15 - 23 mm



**17-842-05**  
60 x 15 - 23 mm



**CLOWARD**  
17-841-01  
17-841-05  
25 cm, 10"

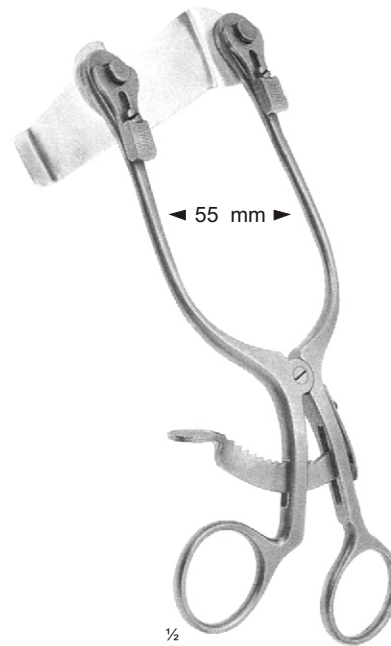

**CLOWARD**  
17-842-01  
17-842-05  
16 cm, 6 1/2"

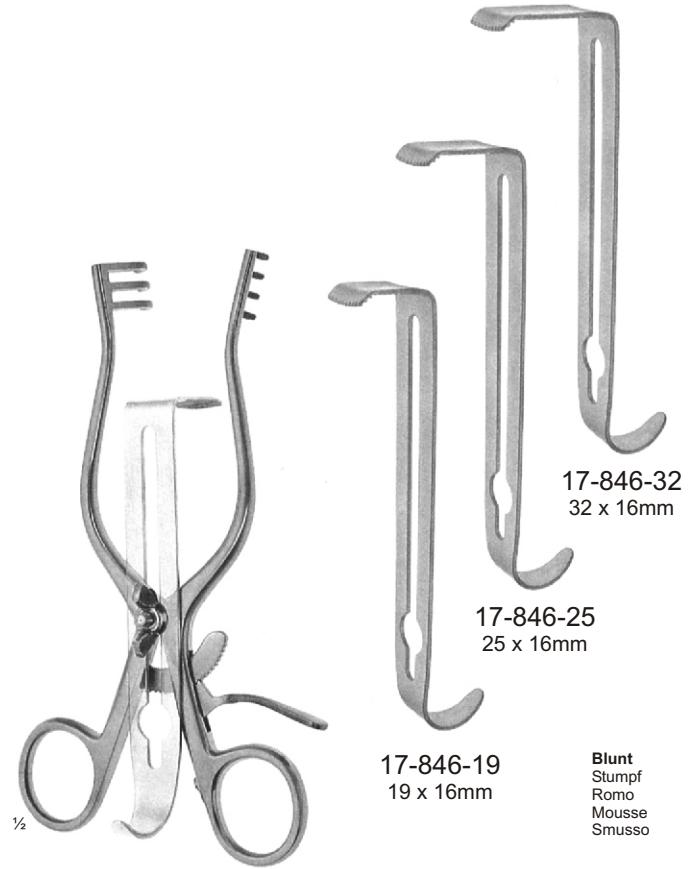
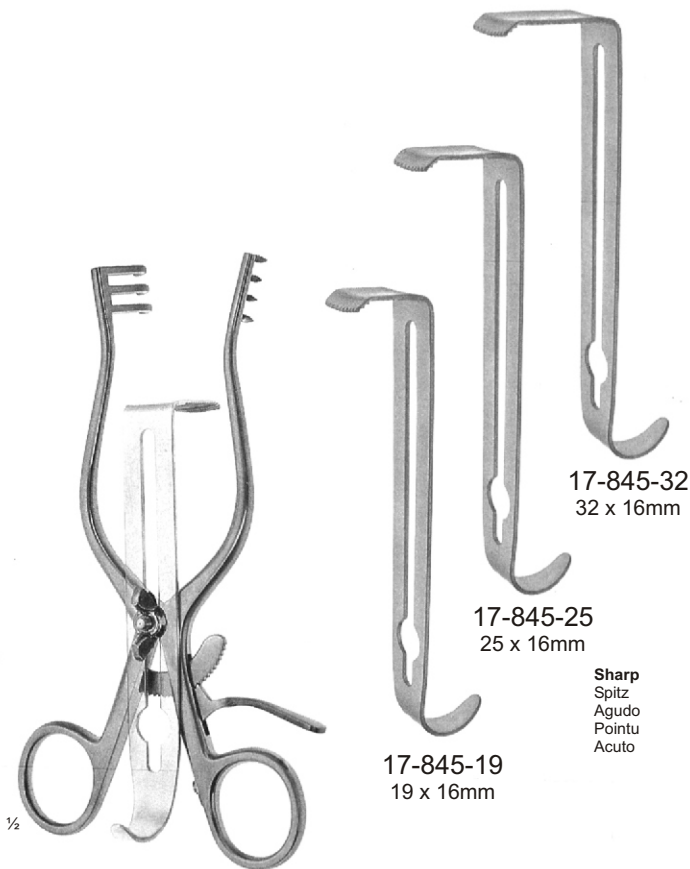

**HENLEY**

17-845-16 17-845-19  
 16,5 cm, 6½" 17-845-32

**HENLEY**

17-846-16 17-846-19  
 16,5 cm, 6½" 17-846-32

**Self-retaining rtractor, complete, consisting of:**  
 17-845-16 1 Spreader with lateral valves, sharp  
 17-845-19 1 Central valve, serrated, 19 x 16 mm  
 17-845-25 1 Central valve, serrated, 25 x 16 mm  
 17-845-32 1 Central valve, serrated, 32 x 16 mm

**Wundspreizer, komplett, bestehend aus:**  
 17-845-16 1 Sperrer mit Seitenvälvn, spitz  
 17-845-19 1 Gezahnten Mittelvalve 19 x 16 mm  
 17-845-25 1 Gezahnten Mittelvalve 25 x 16 mm  
 17-845-32 1 Gezahnten Mittelvalve 32 x 16 mm

**Separador, completo, compuesto de:**  
 17-845-16 1 Separador con valve laterales agudas  
 17-845-19 1 Valva central, dontada, 19 x 16 mm  
 17-845-25 1 Valva central, dentada, 25 x 16 mm  
 17-845-32 1 Valva central, dentada, 32 x 16 mm

**Ecarteur, complet, composé de:**  
 17-845-16 1Ecarteur avec valves laterales, griffes pointues  
 17-845-19 1 Valve central, dentellée 19 x 16 mm  
 17-845-25 1 Valve central, dentellée 25 x 16 mm  
 17-845-32 1 Valve central, dentellée 32 x 16 mm

**Divaricatore, completo, compsto da:**  
 17-845-16 1 Divaricatore con valve laterali, acuto  
 17-845-19 1 Valva central, dentellata, 19 x 16 mm  
 17-845-25 1 Valva central, dentellata, 25 x 16 mm  
 17-845-32 1 Valva central, dentellata, 32 x 16 mm

**Self-retaining rtractor, complete, consisting of:**  
 17-846-16 1 Spreader with lateral valves, blunt  
 17-846-19 1 Central valve, serrated, 19 x 16 mm  
 17-846-25 1 Central valve, serrated, 25 x 16 mm  
 17-846-32 1 Central valve, serrated, 32 x 16 mm

**Wundspreizer, komplett, bestehend aus:**  
 17-846-16 1 Sperrer mit Seitenvälvn, stumpf  
 17-846-19 1 Gezahnten Mittelvalve 19 x 16 mm  
 17-846-25 1 Gezahnten Mittelvalve 25 x 16 mm  
 17-846-32 1 Gezahnten Mittelvalve 32 x 16 mm

**Separador, completo, compuesto de:**  
 17-846-16 1 Separador con valve laterales romas  
 17-846-19 1 Valva central, dontada, 19 x 16 mm  
 17-846-25 1 Valva central, dentada, 25x 16 mm  
 17-846-32 1 Valva central, dentada, 32 x 16 mm

**Ecarteur, complet, composé de:**  
 17-846-01 1Ecarteur avec valves laterales, griffes mousses  
 17-846-02 1 Valve central, dentilé 19 x 16 mm  
 17-846-03 1 Valve central, dentilé 25 x 16 mm  
 17-846-04 1 Valve central, dentilé 32 x 16 mm

**Divaricatore, completo, compsto da:**  
 17-846-01 1 Divaricatore con valve laterali, smusso  
 17-846-02 1 Valva central, dentellata, 19 x 16 mm  
 17-846-03 1 Valva central, dentellata, 28 x 16 mm  
 17-846-04 1 Valva central, dentellata, 32 x 16 mm

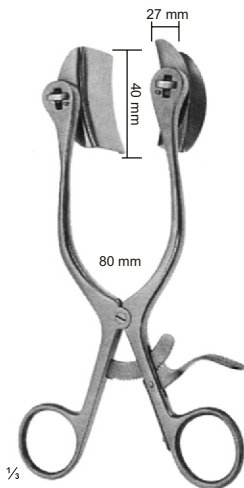
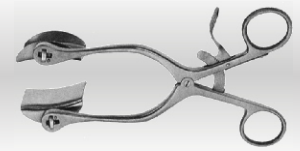

**BABY-COLLIN**  
 17-850-18  
 18 cm, 7"

**Abdominal retractor, complete, consisting of:**  
 17-850-01 1 Spreader  
 17-850-02 1 Pair lateral valves 18 x 40 mm  
 17-850-03 1 Pair lateral valves 27 x 40 mm

Bauchdeckenhalter, komplett, bestehend aus:  
 17-850-01 1 Sperrer  
 17-850-02 1 Paar Seitenvälven 18 x 40 mm  
 17-850-03 1 Paar Seitenvälven 27 x 40 mm

Separador abdominal, completo, compuesto de:  
 17-850-01 1 Separador  
 17-850-02 1 Par de valvas laterales 18 x 40 mm  
 17-850-03 1 Par de valvas laterales 27 x 40 mm

Ecarteur abdominal, complet, composé de:  
 17-850-01 1 Ecarteur  
 17-850-02 1 Paire de valves latérales 18 x 40 mm  
 17-850-03 1 Paire de valves latérales 27 x 40 mm

Divaricatore addominale, completo, compsto da:  
 17-850-01 1 Divaricatore  
 17-850-02 1 Paio di valve laterali 18 x 40 mm  
 17-850-03 1 Paio di valve laterali 27 x 40 mm

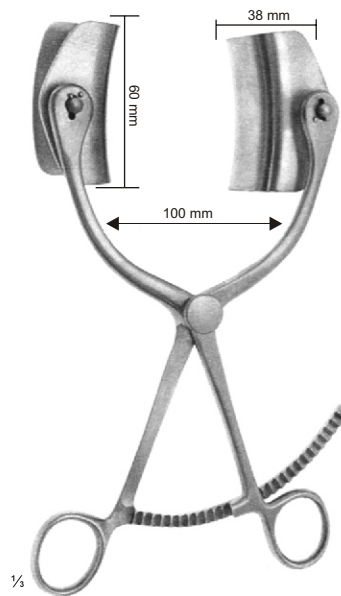

**COLLIN**  
 17-856-23  
 23 cm, 9"

**Abdominal retractor, complete consisting of:**  
 17-856-01 1 Spreader  
 17-856-02 1 Pair lateral valves 38 x 60 mm

Bauchdeckenhalter, komplett, bestehend aus:  
 17-856-01 1 Sperrer  
 17-856-02 1 Paar Seitenvälven 38 x 60 mm

Separador abdominal, completo, compuesto de:  
 17-856-01 1 Separador  
 17-856-02 1 Par de valvas laterales 38 x 60 mm

Ecarteur abdominal, complet, composé de:  
 17-856-01 1 Ecarteur  
 17-856-02 1 Paire de valves latérales 38 x 60 mm

Divaricatore addominale, completo, composto da:  
 17-856-01 1 Divaricatore  
 17-856-02 1 Paio di valve laterali 38 x 60 mm

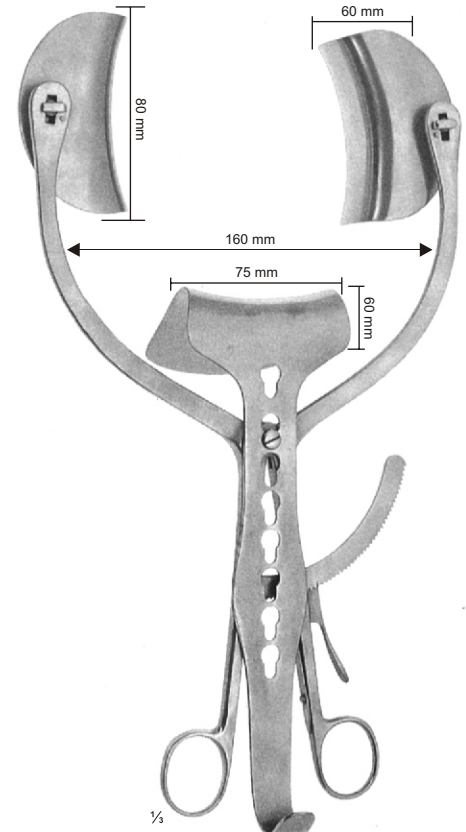

**COLLIN-LOKTITE**  
 17-859-26  
 26 cm, 10½"

**Abdominal retractor, complete consisting of:**  
 17-859-01 1 Spreader  
 17-859-02 1 Pair lateral valves 60 x 80 mm  
 17-859-03 1 Mittelvalve 60 x 75 mm

Bauchdeckenhalter, komplett, bestehend aus:  
 17-859-01 1 Sperrer  
 17-859-02 1 Paar Seitenvälven 60 x 80 mm  
 17-859-03 1 Central valve 60 x 75 mm

Separador abdominal, completo, compuesto de:  
 17-859-01 1 Separador  
 17-859-02 1 Par de valvas laterales 60 x 80 mm  
 17-859-03 1 Valva central 60 x 75 mm

Ecarteur abdominal, complet, composé de:  
 17-859-01 1 Ecarteur  
 17-859-02 1 Paire de valves latérales 60 x 80 mm  
 17-859-03 1 Valva centrale 60 x 75 mm

Divaricatore addominale, completo, composto da:  
 17-859-01 1 Divaricatore  
 17-859-02 1 Paio di valve laterali 60 x 80 mm  
 17-859-03 1 Valva centrale 60 x 75 mm

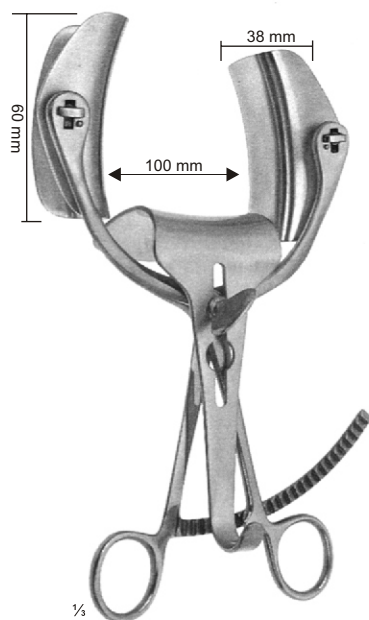

**COLLIN**  
 17-860-25  
 25 cm, 9½"

**Abdominal retractor, complete, consisting of:**  
 17-860-01 1 Spreader  
 17-860-02 1 Pair lateral valves 38 x 80 mm  
 17-860-03 1 Pair lateral valves 55 x 55 mm

Bauchdeckenhalter, komplett, bestehend aus:  
 17-860-01 1 Sperrer  
 17-860-02 1 Paar Seitenvalven 38 x 80 mm  
 17-860-03 1 Paar Seitenvalven 55 x 55 mm

Separador abdominal, completo, compuesto de:  
 17-860-01 1 Separador  
 17-860-02 1 Par de valvas laterales 38 x 80 mm  
 17-860-03 1 Par de valvas laterales 55 x 55 mm

Ecarteur abdominal, complet, composé de:  
 17-860-01 1 Ecarteur  
 17-860-02 1 Paire de valves latérales 38 x 80 mm  
 17-860-03 1 Paire de valves latérales 55 x 55 mm

Divaricatore addominale, completo, composto da:  
 17-860-01 1 Divaricatore  
 17-860-02 1 Paio di valve laterali 38 x 80 mm  
 17-860-03 1 Paio di valve laterali 55 x 55 mm

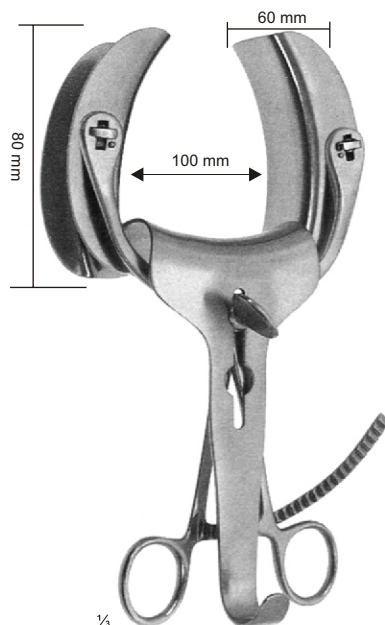

**COLLIN**  
 17-862-26  
 26 cm, 10¼"

**Abdominal retractor, complete, consisting of:**  
 17-862-01 1 Spreader  
 17-862-02 1 Pair lateral valves 40 x 100 mm  
 17-862-03 1 Pair lateral valves 55 x 75 mm

Bauchdeckenhalter, komplett, bestehend aus:  
 17-862-01 1 Sperrer  
 17-862-02 1 Paar Seitenvalven 40 x 100 mm  
 17-862-03 1 Paar Seitenvalven 55 x 75 mm

Separador abdominal, completo, compuesto de:  
 17-862-01 1 Separador  
 17-862-02 1 Par de valvas laterales 40 x 100 mm  
 17-862-03 1 Par de valvas laterales 55 x 75 mm

Ecarteur abdominal, complet, composé de:  
 17-862-01 1 Ecarteur  
 17-862-02 1 Paire de valves latérales 40 x 100 mm  
 17-862-03 1 Paire de valves latérales 55 x 75 mm

Divaricatore addominale, completo, composto da:  
 17-862-01 1 Divaricatore  
 17-862-02 1 Paio di valve laterali 40 x 100 mm  
 17-862-03 1 Paio di valve laterali 55 x 75 mm

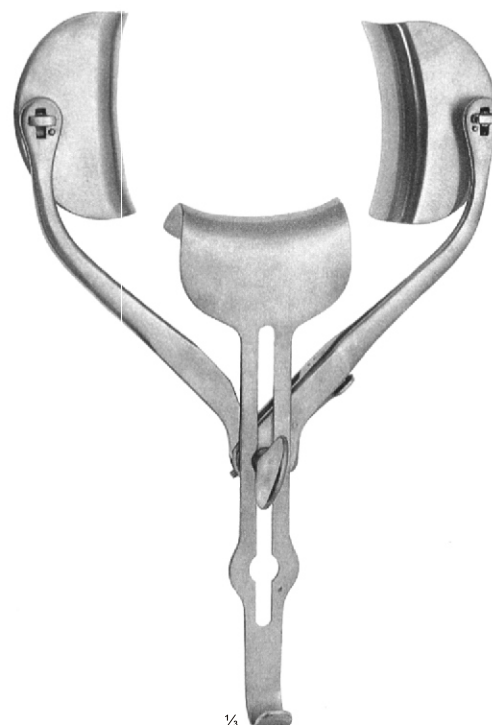

**RICARD**  
 17-870-28  
 28 cm, 11"  
 17-870-30  
 30 cm, 12"

**Abdominal retractor, complete consisting of:**  
 17-870-01 1 Spreader  
 17-870-02 1 Pair lateral valves 60 x 80 mm  
 17-870-03 1 Mittelvalve 55 x 70 mm

Bauchdeckenhalter, komplett, bestehend aus:  
 17-870-01 1 Sperrer  
 17-870-02 1 Paar Seitenvalven 60 x 80 mm  
 17-870-03 1 Central valve 55 x 70 mm

Separador abdominal, completo, compuesto de:  
 17-870-01 1 Separador  
 17-870-02 1 Par de valvas laterales 60 x 80 mm  
 17-870-03 1 Valva central 55 x 70 mm

Ecarteur abdominal, complet, composé de:  
 17-870-01 1 Ecarteur  
 17-870-02 1 Paire de valves latérales 60 x 80 mm  
 17-870-03 1 Valva centrale 55 x 70 mm

Divaricatore addominale, completo, composto da:  
 17-870-01 1 Divaricatore  
 17-870-02 1 Paio di valve laterali 60 x 80 mm  
 17-870-03 1 Valva centrale 55 x 70 mm

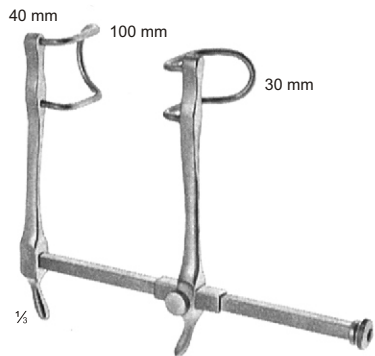
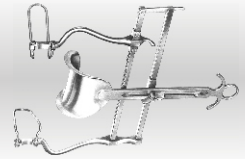

**GOSSET-BABY**  
 17-880-00

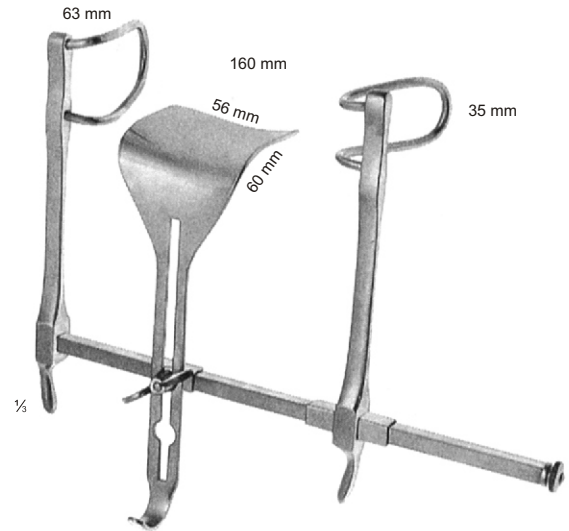

**GOSSET**  
 17-884-00  
 Set , Setz , Juego , Jeu , Serie

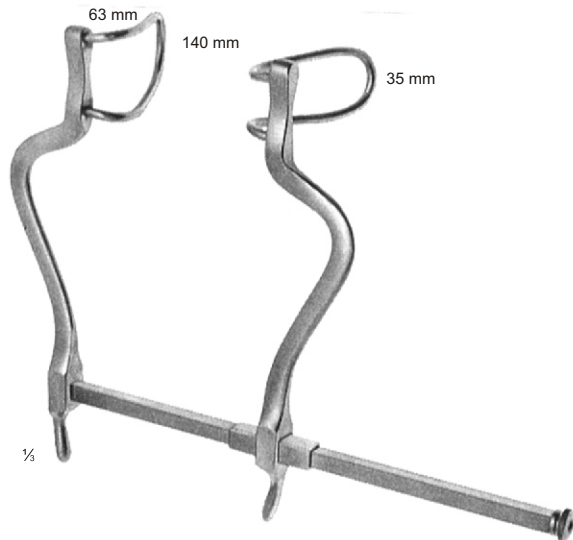

**GOSSET**  
 17-882-00

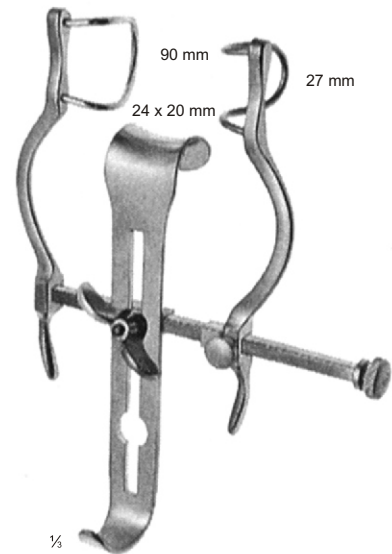

**BALFOUR-BABY**  
 17-890-00  
 Set , Setz , Juego , Jeu , Serie

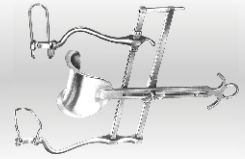

**BALFOUR**  
 17-892-00 180mm  
 17-892-01 200mm  
 Set , Setz , Juego , Jeu , Serie



**BALFOUR**  
 17-894-00 180mm  
 17-894-01 200mm  
 Set , Setz , Juego , Jeu , Serie

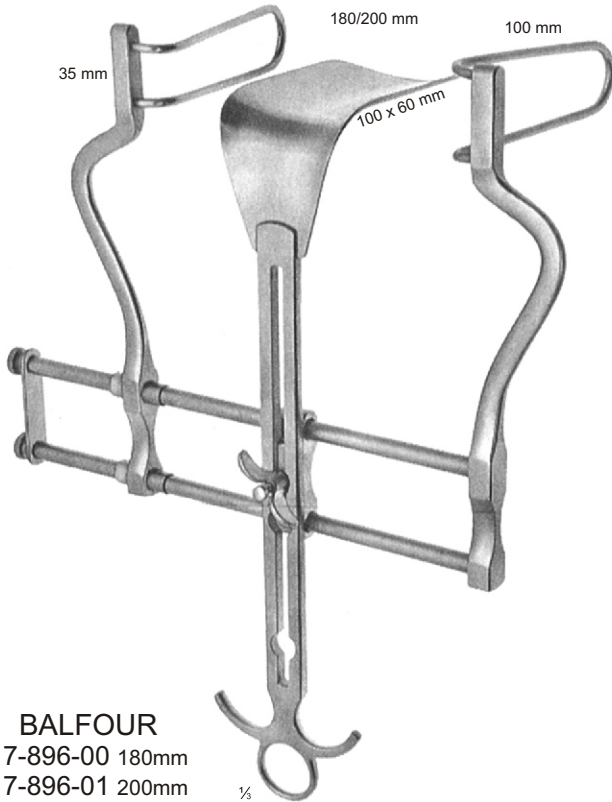

**BALFOUR**  
 17-896-00 180mm  
 17-896-01 200mm  
 Set , Setz , Juego , Jeu , Serie

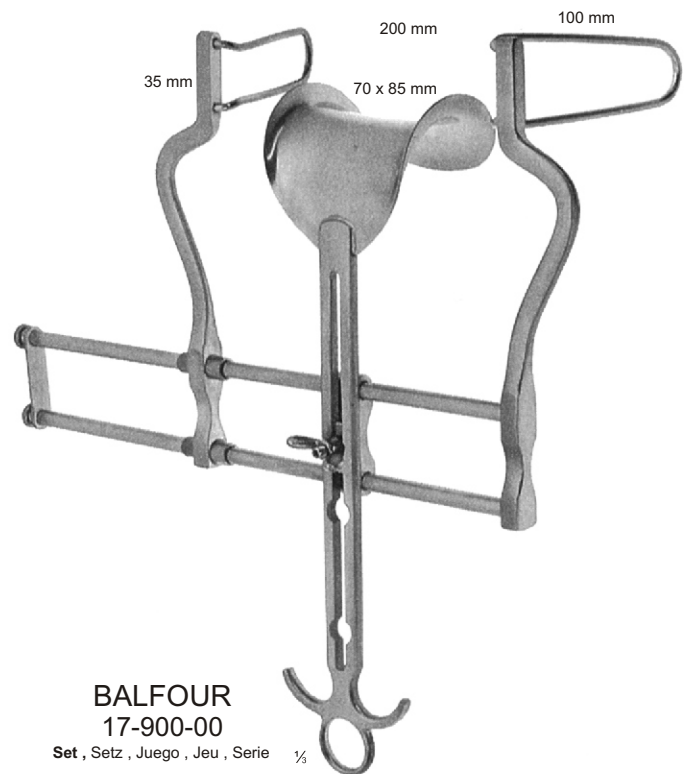

**BALFOUR**  
 17-900-00  
 Set , Setz , Juego , Jeu , Serie



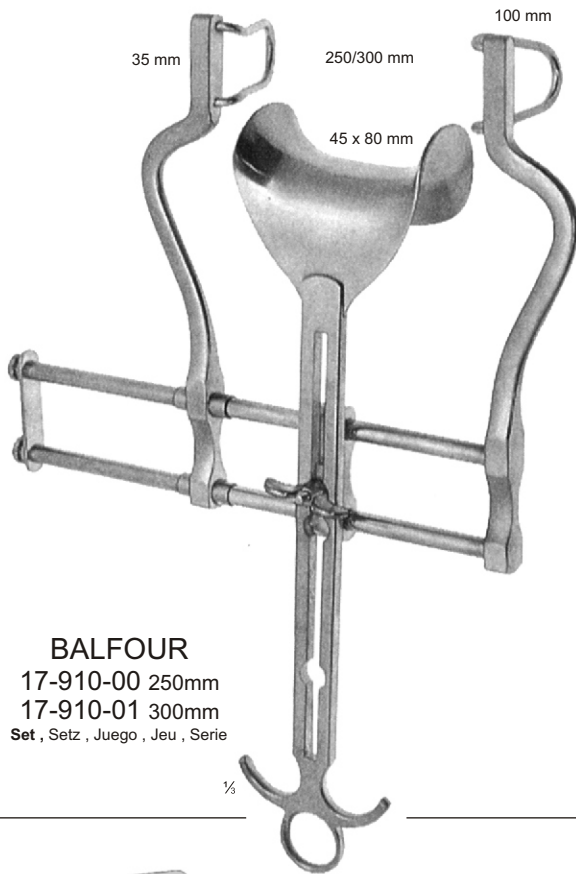
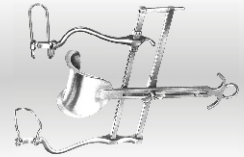

**BALFOUR**  
 17-910-00 250mm  
 17-910-01 300mm  
 Set , Setz , Juego , Jeu , Serie

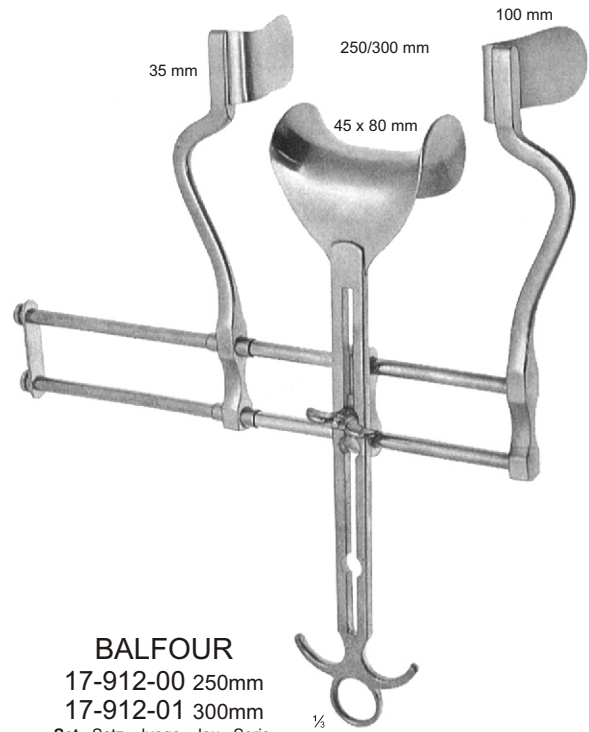

**BALFOUR**  
 17-912-00 250mm  
 17-912-01 300mm  
 Set , Setz , Juego , Jeu , Serie



**BALFOUR-US TYPE**  
 17-920-00

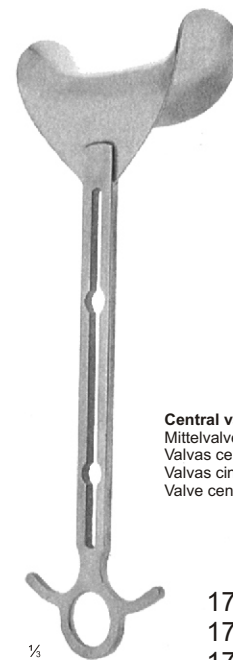

**Central valves, for abdominal retractors**  
 Mittelvalven für Bauchdeckenhalter  
 Valvas centrales, para separadores abdominales  
 Valvas cintrales, pour écarteurs abdominaux  
 Valve centrali, per divaricatori addominali

**BALFOUR**  
 17-914-01 45 x 80 mm  
 17-914-02 70 x 85 mm  
 17-914-03 45 x 90 mm

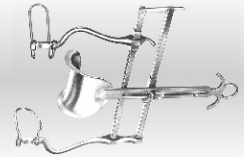

**ROCHARD**  
17-930-01

**Mounting frame for fastening to both sides of the lateral bare 25 x 10 mm of the operating tables, can be dismantled for sterilization**

Befestigungsgestell mit beidseitiger Fixierung an den seitenschienen 25 x 10 mm der OP-Tische, zur Sterilisation zerigbar

Bastidor para la fijación a las ambas barras laterales 25 x 10 mm de las mesas de operación, plegable para la esterilización

Cadre se fixant aux barres latérales 25 x 10 mm de chaques côtés de la table d'opération, pliable pour stérilisation

Telaio di supporto per il fissaggio alla barre laterale 25 x 10 mm del tavolo operatorio può essere smontato per la sterilizzazione



**ROCHARD**  
17-938-19  
19,5 cm, 7¾"

**Fixation device for 17-966-01\_17-966-05**  
 Fixiervorrichtung für 17-966-01\_17-966-05  
 Dispositivo de fijación para 17-966-01\_17-966-05  
 Compas articulé pour 17-966-01\_17-966-05  
 Dispositivo di fissaggio per 17-966-01\_17-966-05

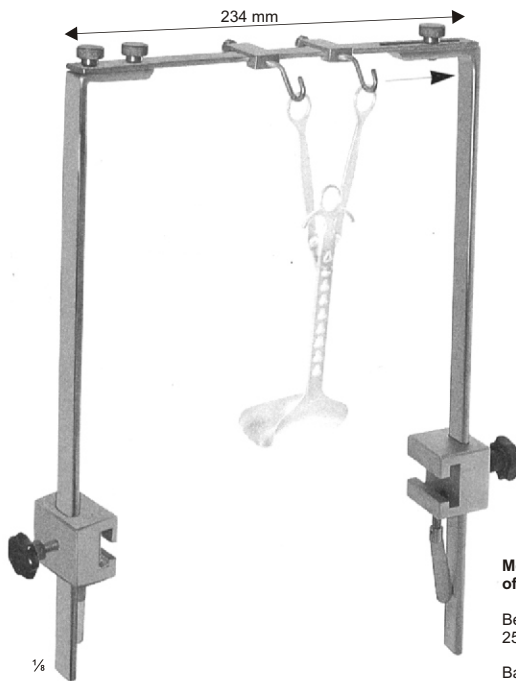

**ROCHARD**  
17-930-02

**Mounting frame for fastening to the lateral bare 25 x 10 mm of the operating tables, can be dismantled for sterilization**

Befestigungsgestell mit beidseitiger Fixierung an den seitenschienen 25 x 10 mm der OP-Tische, zur Sterilisation zeriegbar

Bastidor para la fijación a las ambas laterales 25 x 10 mm de las mesas de operación, plegable para la esterilización

Cadre se fixant aux barres latérales 25 x 10 mm de chaques côtés de la table d'opération, pliable pour stérilisation

Telaio di per il fissaggio alla barra laterale 25 x 10 mm del tavolo operatorio può essere smontato per la sterilizzazione

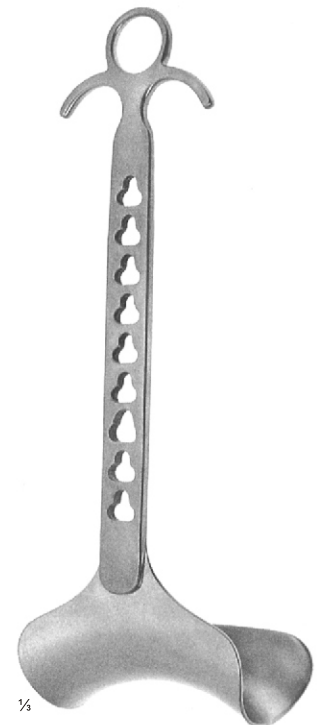

**ROCHARD**  
 17-936-01 50 x 90 mm  
 17-936-02 50 x 105 mm  
 17-936-03 50 x 120 mm  
 17-936-04 50 x 135 mm  
 17-936-05 50 x 155 mm  
 29 cm, 11½"

**Abdominal retractors**  
 Bauchdeckenhaken  
 Separadores abdominales  
 Ecarteur abdominal  
 Divaricatore addominale

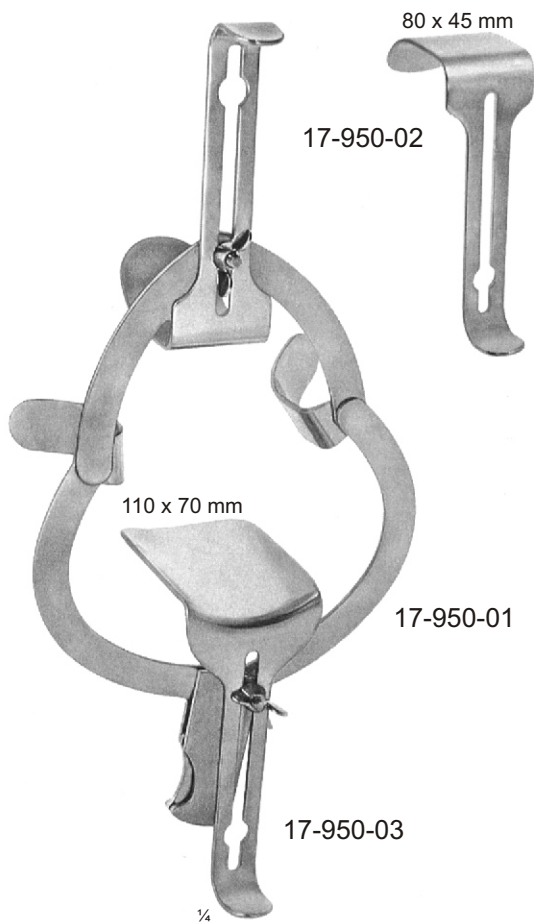
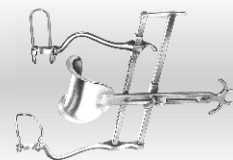

**O'SULLIVAN-O'CONNOR**  
 17-950-00

**Abdominal rtractor, complete, consisting of:**  
 17-950-01 1 Frame  
 17-950-02 2 Valves 80 x 45 mm  
 17-950-03 1 Valve 110 x 70 mm

Bauchdeckenhalter, komplett, bestehend aus:  
 17-950-01 1 Rahmen  
 17-950-02 2 Valven 80 x 45 mm  
 17-950-03 1 Valve 110 x 70 mm

Separador abdominal, completo, compuesto de:  
 17-950-01 1 Cuadro  
 17-950-02 2 Valvas 80 x 45 mm  
 17-950-03 1 Valva 110 x 70 mm

Ecarteur abdominal, complet, composé de:  
 17-950-01 1 Cadre  
 17-950-02 2 Valves 80 x 45 mm  
 17-950-03 1 Valve 110 x 70 mm

Divaricatore addominale, completo, compsto da:  
 17-950-01 1 Telaio  
 17-950-02 2 Valve 80 x 45 mm  
 17-950-03 1 Valva 110 x 70 mm

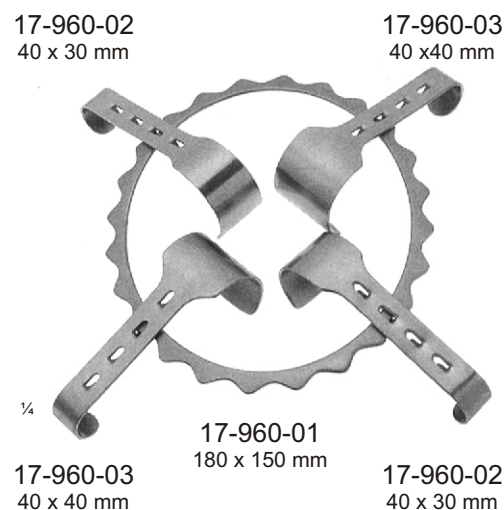

**DENIS-BROWNE**

17-960-00 180 x 150 mm  
 17-960-01 255 x 180 mm

**Abdominal rtractor, complete, consisting of:**  
 17-925-01 1 Frame 180 x 150 mm  
 17-925-02 2 Valves 40 x 30 mm  
 17-925-03 1 Valves 40 x 40 mm

Bauchdeckenhalter, komplett, bestehend aus:  
 17-925-01 1 Rahmen 180 x 150 mm  
 17-925-02 2 Valven 40 x 30 mm  
 17-925-03 1 Valven 40 x 40 mm

Separador abdominal, completo, compuesto de:  
 17-925-01 1 Cuadro 180 x 150 mm  
 17-925-02 2 Valvas 40 x 30 mm  
 17-925-03 1 Valvas 40 x 40 mm

Ecarteur abdominal, complet, composé de:  
 17-925-01 1 Cadre 180 x 150 mm  
 17-925-02 2 Valves 40 x 30 mm  
 17-925-03 1 Valvas 40 x 40 mm

Divaricatore addominale, completo, composto da:  
 17-925-01 1 Telaio 180 x 150 mm  
 17-925-02 2 Valve 40 x 30 mm  
 17-925-03 1 Valve 40 x 40 mm

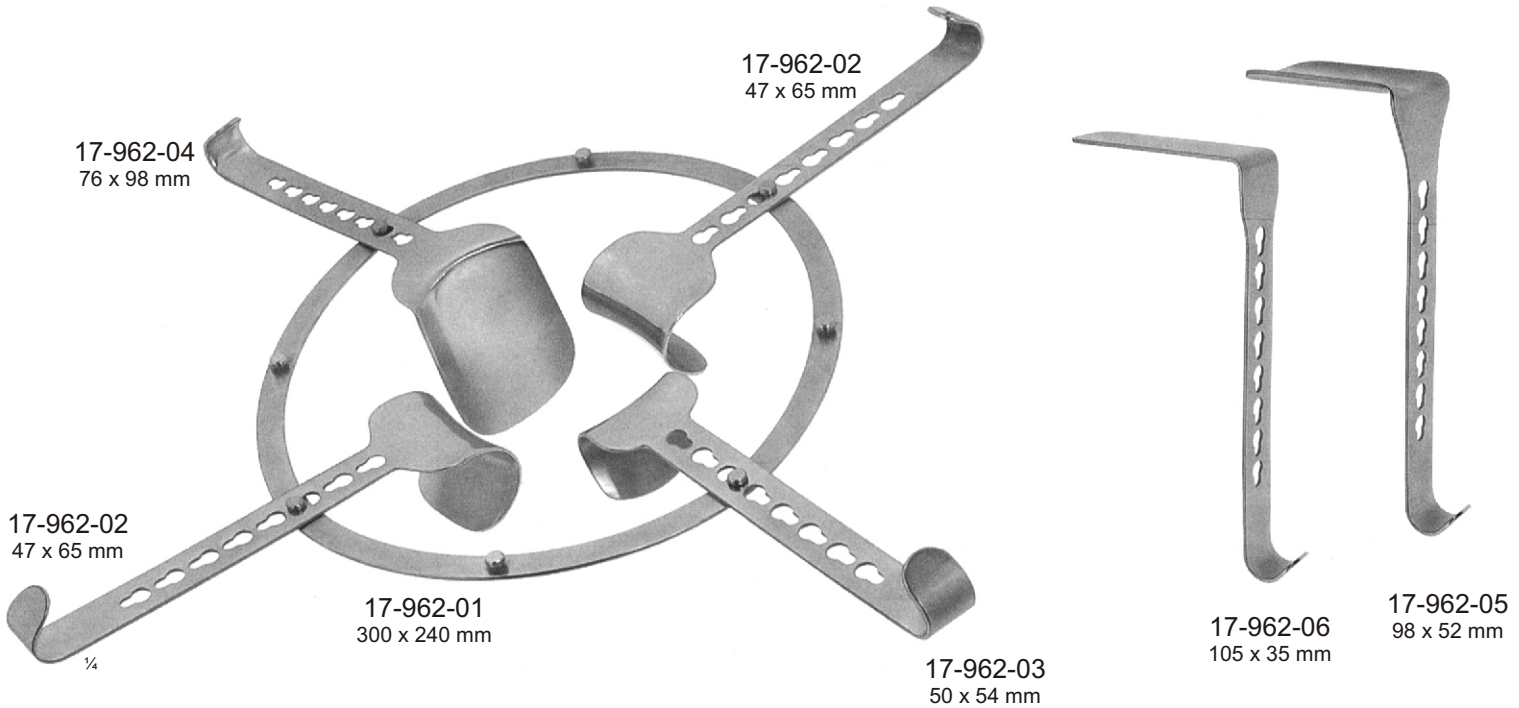
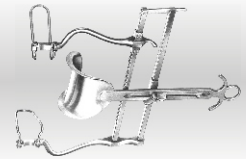

**SEMM**  
 17-962-00

Set , Setz , Juego , Jeu , Serie

**Abdominal retractor, complete, consisting of:**  
 17-962-01 1 Cadre 275 x 250 mm  
 17-962-02 2 Valves 47 x 65 mm  
 17-962-03 1 Valve for bladder 50 x 54 mm  
 17-962-04 1 Valve for intestine 76 x 98 mm  
 17-962-05 1 Valve for intestine 98 x 52 mm  
 17-962-06 1 Valve 105 x 35 mm

Ecarteur abdominal, complet, composé de:  
 17-962-01 1 Cadre 275 x 250 mm  
 17-962-02 2 Valves 47 x 65 mm  
 17-962-03 1 Valve pour vessie 50 x 54 mm  
 17-962-04 1 Valve pour intestin 76 x 98 mm  
 17-962-05 1 Valve pour intestin 98 x 52 mm  
 17-962-06 1 Valve 105 x 35 mm

**Bauchdeckenhalter, komplett, bestehend aus:**  
 17-962-01 1 Rahmen 275 x 250 mm  
 17-962-02 2 Valven 47 x 65 mm  
 17-962-03 1 Valve für die Blase 50 x 54 mm  
 17-962-04 1 Valve für den Darm 76 x 98 mm  
 17-962-05 1 Valve für den Darm 98 x 52 mm  
 17-962-06 1 Valve 105 x 35 mm

Divaricatore addominale, completo, composto da:  
 17-962-01 1 Telaio 275 x 250 mm  
 17-962-02 1 Valve 47 x 65 mm  
 17-962-03 1 Valva per vescica 50 x 54 mm  
 17-962-04 1 Valva per intestino 76 x 98 mm  
 17-962-05 1 Valva per intestino 98 x 52 mm  
 17-962-06 1 Valva 105 x 35 mm

**Separador abdominal, completo, compuesto de:**  
 17-962-01 1 Cuadro 275 x 250 mm  
 17-962-02 2 Valvas 47 x 65 mm  
 17-962-03 1 Valva para vejiga 50 x 54 mm  
 17-962-04 1 Valva para intestino 76 x 98 mm  
 17-962-05 1 Valva para intestino 98 x 52 mm  
 17-962-06 1 Valva 105 x 35 mm

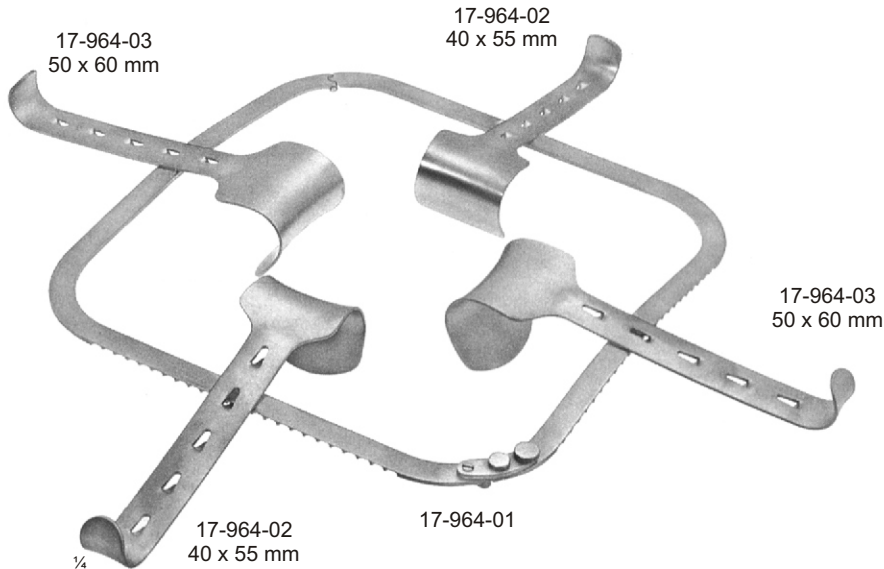
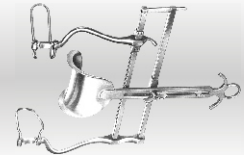

**KIRSCHNER**  
**17-964-00**

Set , Setz , Juego , Jeu , Serie

**Abdominal Retractor, complete, consisting of:**  
 17-964-01 1 Folding frame 255 x 255 mm  
 17-964-02 2 Valves 40 x 55 mm  
 17-964-03 2 Valves 50 x 60 mm

Bauchdeckenhalter, komplett, bestehend aus:  
 17-964-01 1 zusammenlegbarer Rahmen 255 x 255 mm  
 17-964-02 2 Valven 40 x 55 mm  
 17-964-03 2 Valven 50 x 60 mm

Separador abdominal, completo, compuesto de:  
 17-964-01 1 Cuadro plegable 255 x 255 mm  
 17-964-02 2 Valvas 40 x 55 mm  
 17-964-03 2 Valvas 50 x 60 mm

Ecarteur abdominal, complet, composé de:  
 17-964-01 1 Cadre pliant 255 x 255 mm  
 17-964-02 2 Valves 40 x 55 mm  
 17-964-03 2 Valves 50 x 60 mm

Divaricatore addominale, completo, composto da:  
 17-964-01 1 Telaio pieghevole 255 x 255 mm  
 17-964-02 2 Valve 40 x 55 mm  
 17-964-03 2 Valve 50 x 60 mm

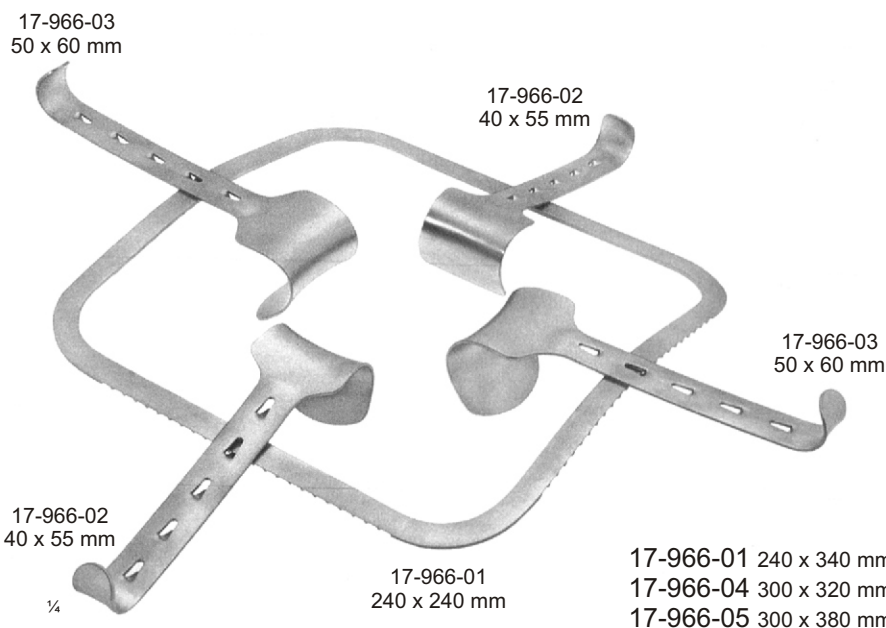

**KIRSCHNER**  
**17-966-02**

Set , Setz , Juego , Jeu , Serie

**Abdominal Retractor, complete, consisting of:**  
 17-966-01 1 Fixed frame 240 x 240 mm  
 17-966-02 2 Valves 40 x 55 mm  
 17-966-03 2 Valves 50 x 60 mm

Bauchdeckenhalter, komplett, bestehend aus:  
 17-966-01 1 starrer Rahmen 240 x 240 mm  
 17-966-02 2 Valven 40 x 55 mm  
 17-966-03 2 Valven 50 x 60 mm

Separador abdominal, completo, compuesto de:  
 17-966-01 1 Cuadro fijo 240 x 240 mm  
 17-966-02 2 Valvas 40 x 55 mm  
 17-966-03 2 Valvas 50 x 60 mm

Ecarteur abdominal, complet, composé de:  
 17-966-01 1 Cadre fixe 240 x 240 mm  
 17-966-02 2 Valve 40 x 55 mm  
 17-966-03 2 Valve 50 x 60 mm

Divaricatore addominale, completo, composto da:  
 17-966-01 1 Telaio pieghevole 240 x 240 mm  
 17-966-02 2 Valve 40 x 55 mm  
 17-966-03 2 Valve 50 x 60 mm

**Fixed frames**  
 Starre Rahmen  
 Cuadros fijos  
 Cadres fixe  
 Telaio fisso

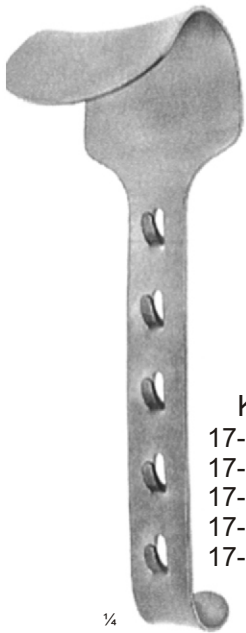
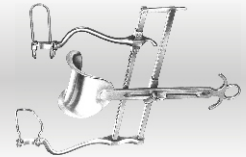

**KIRSCHNER**

- 17-970-01 40x55mm
- 17-970-02 50x65mm
- 17-970-03 60x85mm
- 17-970-04 78x65mm
- 17-970-05 80x90mm

¼



**KIRSCHNER  
BALFOUR**

- 17-972-01
- 17-972-02
- 78x65mm
- 80x90mm

¼



**STANDARD**

- 17-974-01
- 17-974-02
- 17-974-03
- 40x55mm
- 50x65mm
- 60x85mm

¼



**KIRSCHNER**

- 17-976-01
- 17-976-02
- 98x50mm
- 105x35mm

½

**Laminectomy Retractors**  
 Laminektomie-Spreizer  
 Separadores para laminectomia  
 Ecarteurs pour laminectomie  
 Divaricatori per laminectomia

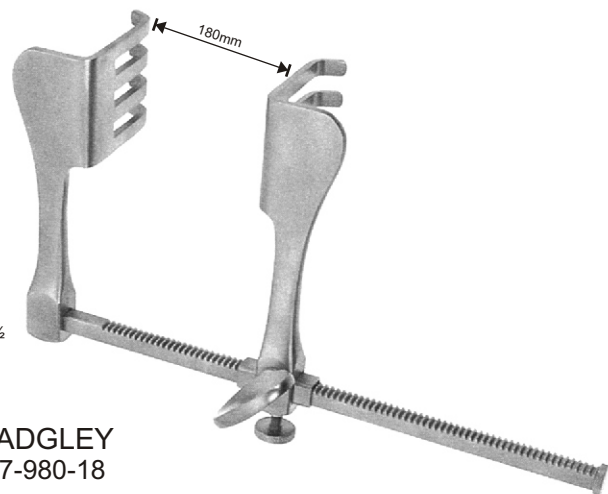

**BADGLEY**  
17-980-18

**Self-retaining retractor, lateral velvies 52 x 22 mm**  
 Wundspreizer, Seitenvalvaen 52 x 22 mm  
 Separador, valvas laterales 52 x 22 mm  
 Ecarteur, valves talérales 52 x 22 mm  
 Divaricatore, valve laterali 52 x 22 mm

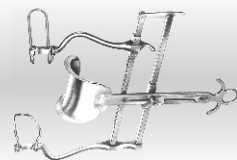

**Self-retaining retractor, complete, consisting of:**

- 17-982-01 1 Frame
- 17-982-01 1 Hook 50mm
- 17-982-03 1 Lateral valve 64 x 25 mm

**Wundspreizer, komplett, bestehend aus:**

- 17-982-01 1 Rahmen
- 17-982-01 1 Haken 50 mm
- 17-982-03 1 Seitenvalve 64 x 25 mm

**Separador, completo, compuesto de:**

- 17-982-01 1 Cuadro
- 17-982-01 1 Gancho 50 mm
- 17-982-03 1 Valva lateral 64 x 25 mm

**Ecarteur, complet, composé de:**

- 17-982-01 1 Cadre
- 17-982-01 1 Crochet 50 mm
- 17-982-03 1 Valve latérale 64 x 25 mm

**Divaricatore, completo, composto da:**

- 17-982-01 1 Telaio
- 17-982-01 1 Divaricatore 50 mm
- 17-982-03 1 Valva laterale 64 x 25 mm

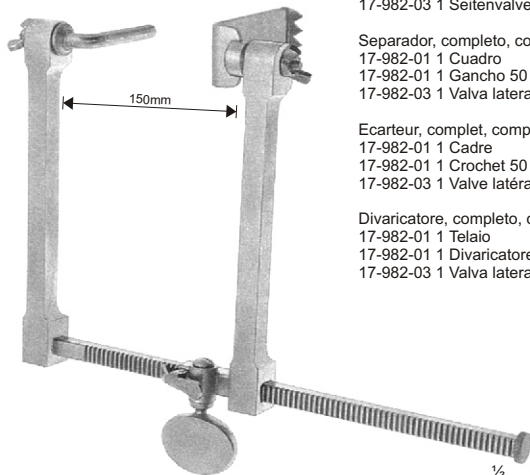

**SCOVILLE**  
17-982-00



**SCOVILLE**  
17-982-01 50 mm  
17-982-02 70 mm

**Hooks for self-retaining retractors 17-982-00 and 17-984-00**

Haken für Wundspreizer  
17-982-00 und 17-984-00

Ganchos para separadores  
17-982-00 y 17-984-00

Crochet pour écarteurs  
17-982-00 et 17-984-00

Gancio per divaricatori  
17-982-00 e 17-984-00



**SCOVILLE**  
17-982-03 64 X 25 mm  
17-982-04 64 X 50 mm  
17-982-05 88 X 25 mm

**Lateral valves for self-retaining retractors 17-982-00 and 17-984-00**

Seitenvalven für Wundspreizer  
17-982-00 und 17-984-00

Valvas laterales para separadores  
17-982-00 y 17-984-00

Valves latérales pour écarteurs  
17-982-00 et 17-984-00

Valve laterali per divaricatori  
17-982-00 e 17-984-00

**With articulated arms**  
 Mit Gelenkarmen  
 Con brazos articulados  
 Avec bras, articulés  
 Con braccio articolato

**Self-retaining retractor, complete, consisting of:**

- 17-984-01 1 Frame
- 17-982-01 1 Hook 50mm
- 17-982-03 1 Lateral valve 64 x 25 mm

**Wundspreizer, komplett, bestehend aus:**

- 17-984-01 1 Rahmen
- 17-982-01 1 Haken 50 mm
- 17-982-03 1 Seitenvalve 64 x 25 mm

**Separador, completo, compuesto de:**

- 17-984-01 1 Cuadro
- 17-982-01 1 Gancho 50 mm
- 17-982-03 1 Valva lateral 64 x 25 mm

**Ecarteur, complet, composé de:**

- 17-984-01 1 Cadre
- 17-982-01 1 Crochet 50mm
- 17-982-03 1 Valve latérale 64 x 25 mm

**Divaricatore, completo, composto da:**

- 17-984-01 1 Telaio
- 17-982-01 1 Divaricatore 50 mm
- 17-982-03 1 Valva laterale 64 x 25 mm

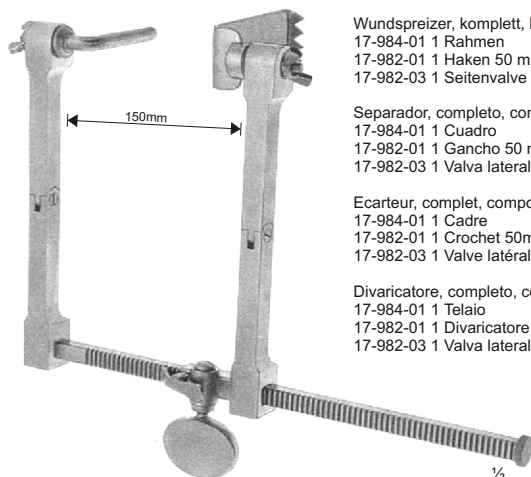

**SCOVILLE-HAVERFIELD**  
17-984-00



**SCOVILLE**  
17-982-06 41 X 38 mm  
17-982-07 67 X 44 mm

**Lateral valves for self-retaining retractors 17-982-12 and 17-984-00**

Seitenvalven für Wundspreizer  
17-982-12 und 17-984-00

Valvas laterales para separadores  
17-982-12 y 17-984-00

Valves latérales pour écarteurs  
17-982-12 et 17-984-00

Valve laterali per divaricatori  
17-982-12 e 17-984-00



**TAYLOR**  
17-982-08 48 X 50 mm  
17-982-09 64 X 50 mm  
17-982-10 64 X 64 mm  
17-982-11 80 X 57 mm

**Lateral valves for self-retaining retractors 17-982-00 and 17-984-00**

Seitenvalven für Wundspreizer  
17-982-00 und 17-984-00

Valvas laterales para separadores  
17-982-00 y 17-984-00

Valves latérales pour écarteurs  
17-982-00 et 17-984-00

Valve laterali per divaricatori  
17-982-00 e 17-984-00